

# EMBODIED CARBON IN BUILDINGS



# EMBODIED CARBON IN BUILDINGS

## Session 3: Design Decisions



**Jean Carroon FAIA**  
BSA President; Goody Clancy



**Stephanie Carlisle**  
KieranTimberlake



**Stacy Smedley**  
Skanska USA



**Mark D. Webster PE**  
Simpson Gumpertz & Heger



**HOW CAN ARCHITECTS DESIGN  
LESS IMPACTFUL BUILDINGS  
IF THEY DON'T MEASURE  
ENVIRONMENTAL IMPACTS?**

**STEPHANIE CARLISLE**  
KIERANTIMBERLAKE ARCHITECTS

TRADITIONAL WORKFLOW

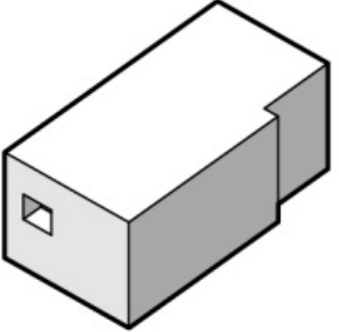

SCHEMATIC DESIGN

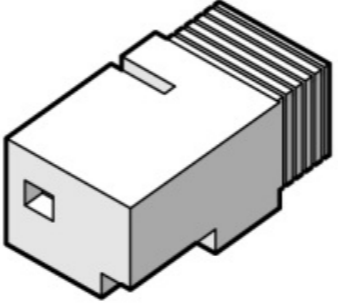

DESIGN DEVELOPMENT

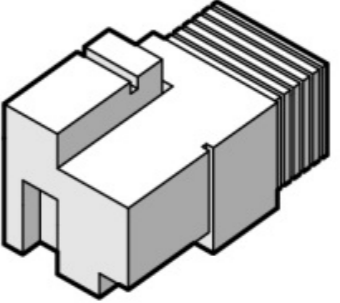

CONSTRUCTION DOCUMENTS



LIFE CYCLE ASSESSMENT

OPTIMAL WORKFLOW

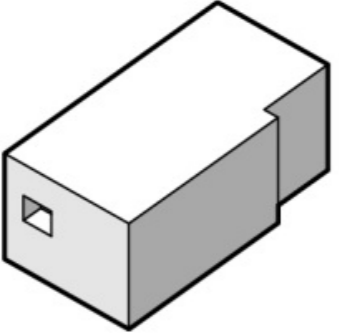

SCHEMATIC DESIGN

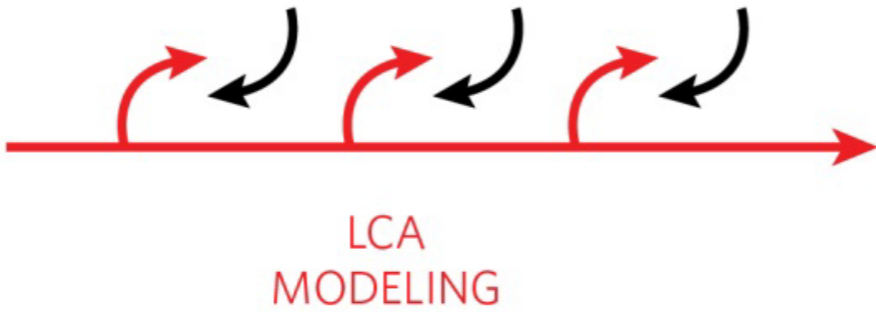
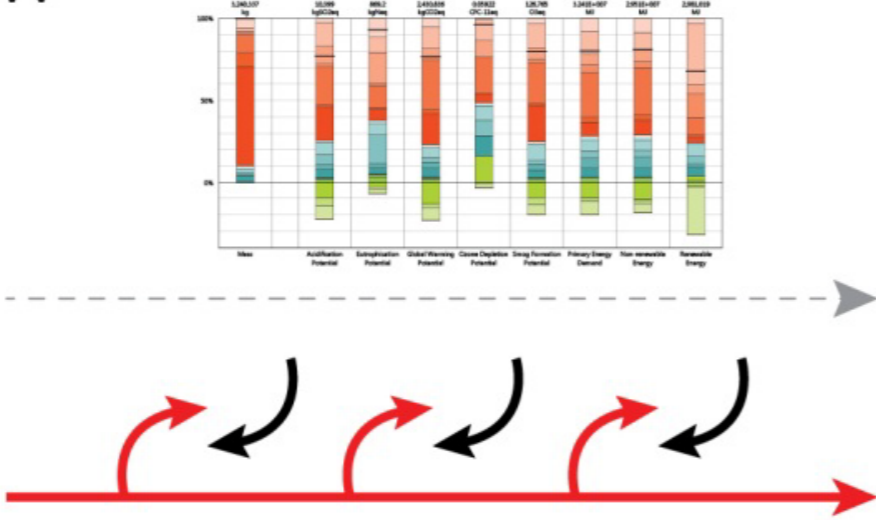

LCA MODELING

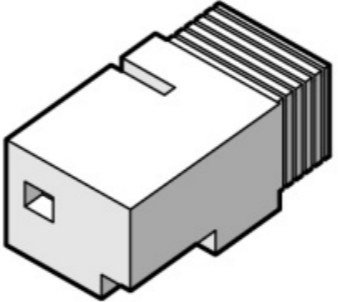

DESIGN DEVELOPMENT

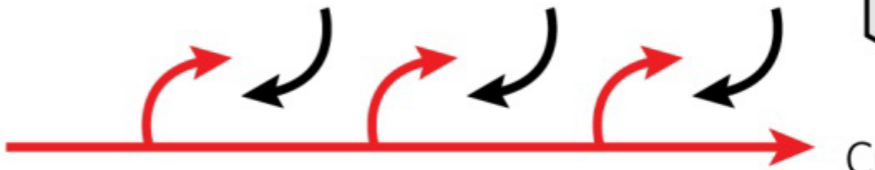
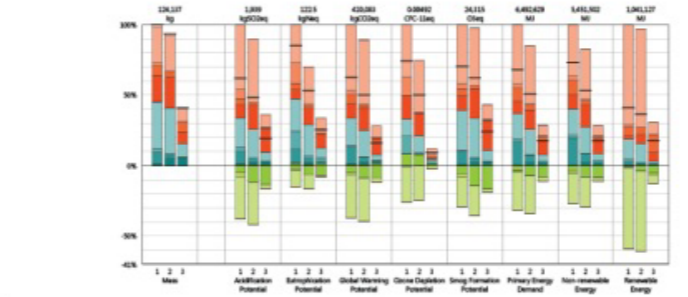

LCA MODELING

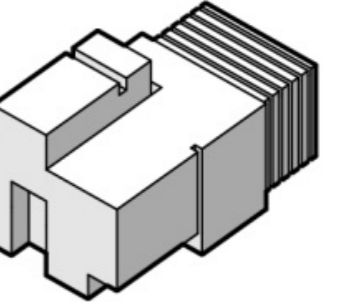

CONSTRUCTION DOCUMENTS



**KT INNOVATIONS**  
An affiliate of Kieran Timberlake



thinkstep

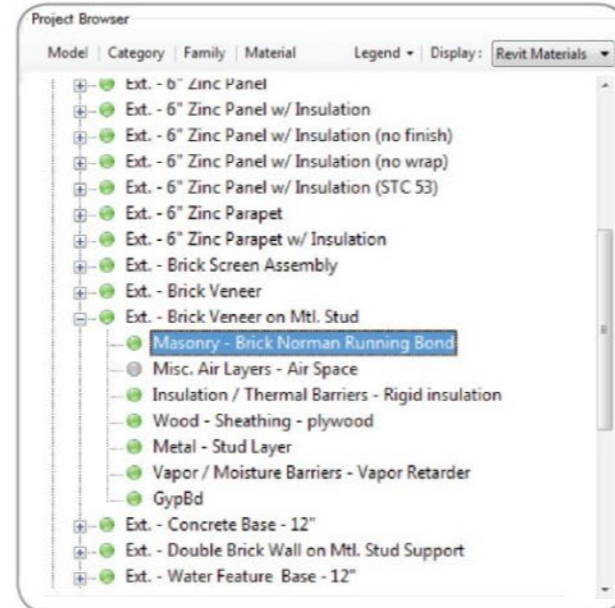
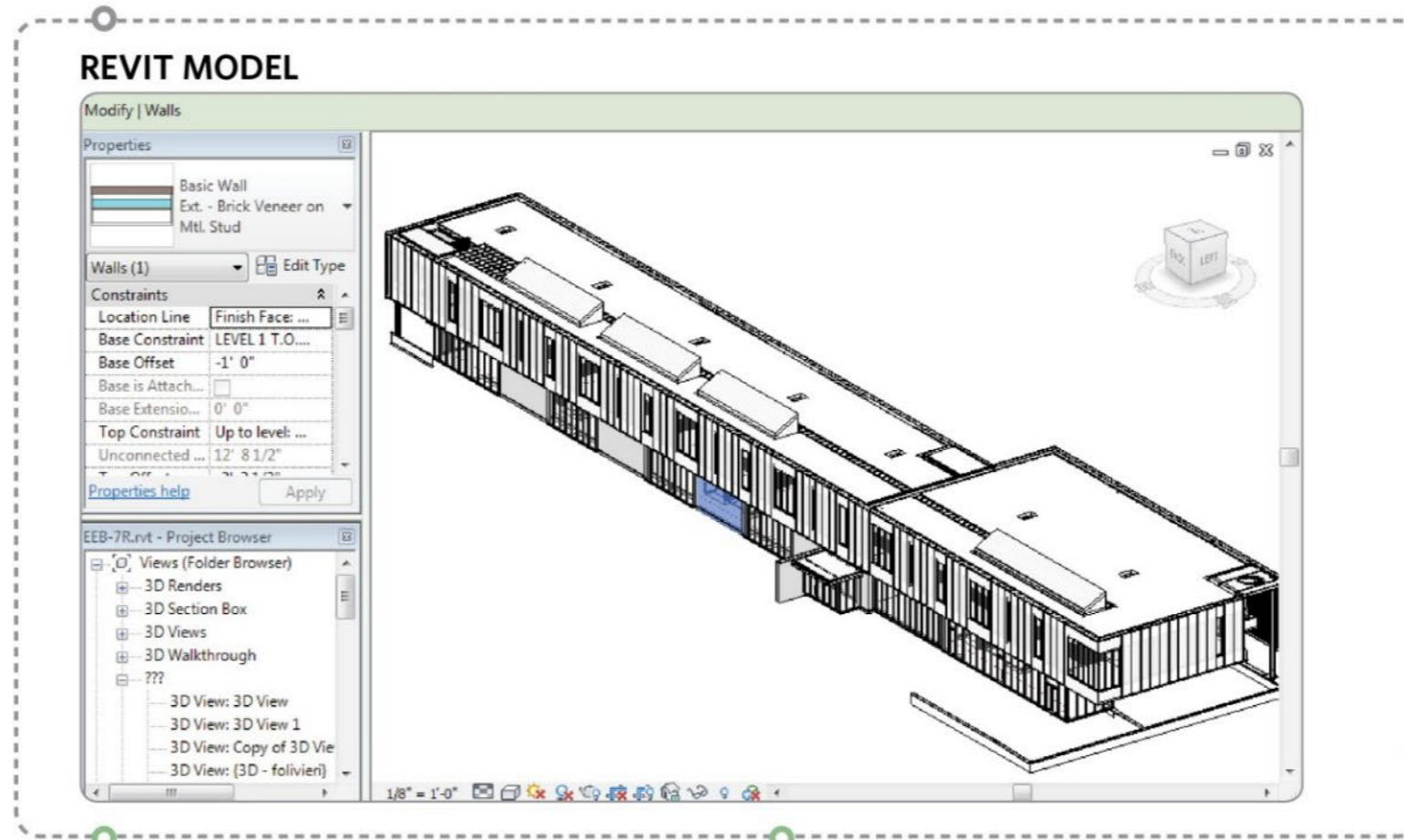

**TALLY™** Material quantities are pulled from the Revit model

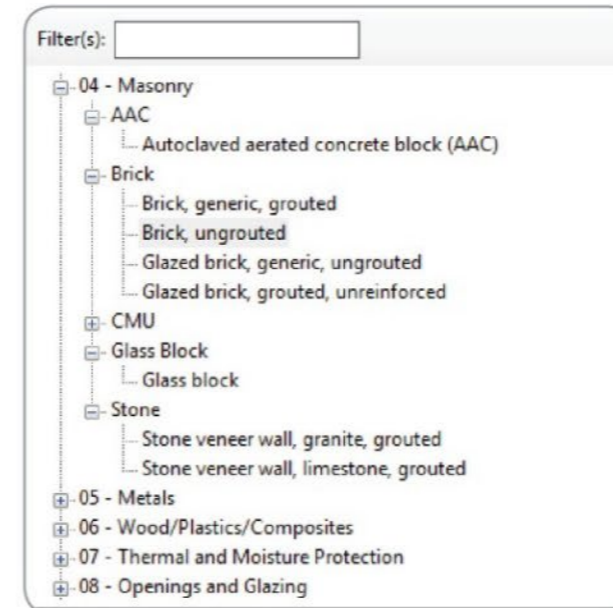

**DATABASE** Impacts are captured in an LCA database

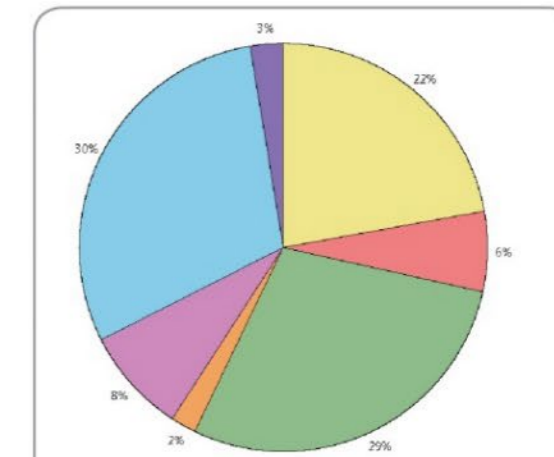

Global Warming Potential

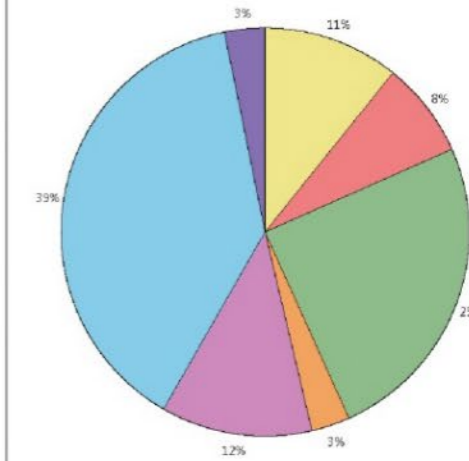

Primary Energy Demand

**LEGEND**

- 03 - Concrete
- 04 - Masonry
- 05 - Metals
- 06 - Wood/Plastics/Composites
- 07 - Thermal and Moisture Protection
- 08 - Openings and Glazing
- 09 - Finishes

**TALLY™ REPORT** Design and material selection questions are rapidly answered

# 1. **EARLY-PHASE WHOLE BUILDING LCA**

Part to whole, Rough, focus on typologies, assemblies and materials, not products

# 2. **DESIGN OPTION MODELS**

Targeted design questions, detailed comparisons

# 3. **END-OF-PROJECT BENCHMARKING**

Construction documentation, Project narratives

How did we do?



Global Warming Potential

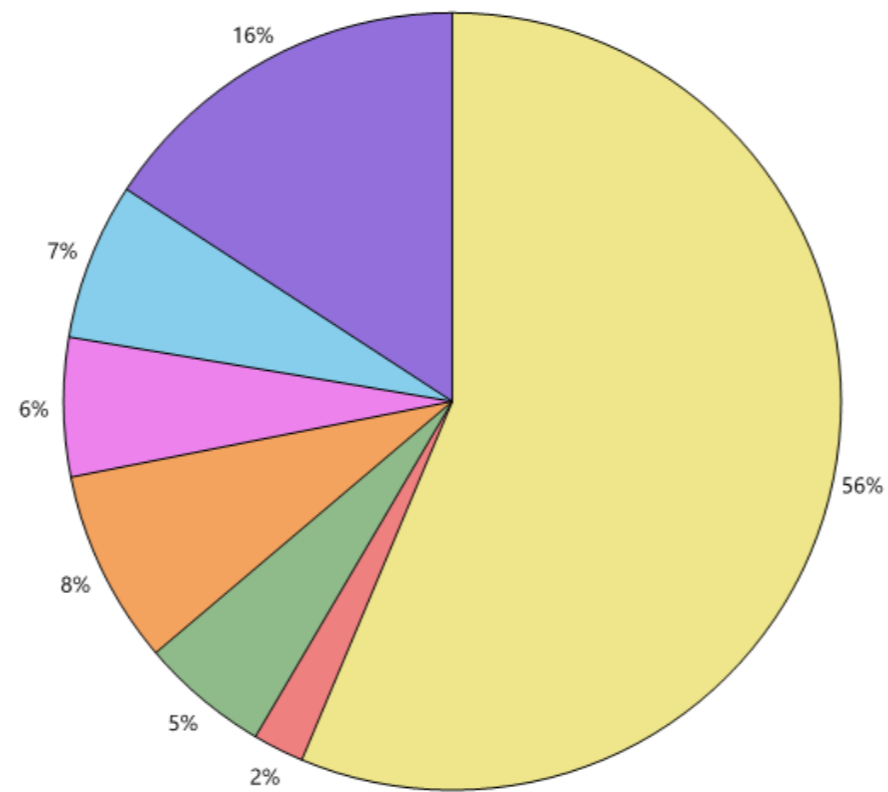

Global Warming Potential

CSI Divisions

- 03 - Concrete
- 04 - Masonry
- 05 - Metals
- 06 - Wood/Plastics/Composites
- 07 - Thermal and Moisture Protection
- 08 - Openings and Glazing
- 09 - Finishes

Results per CSI Division

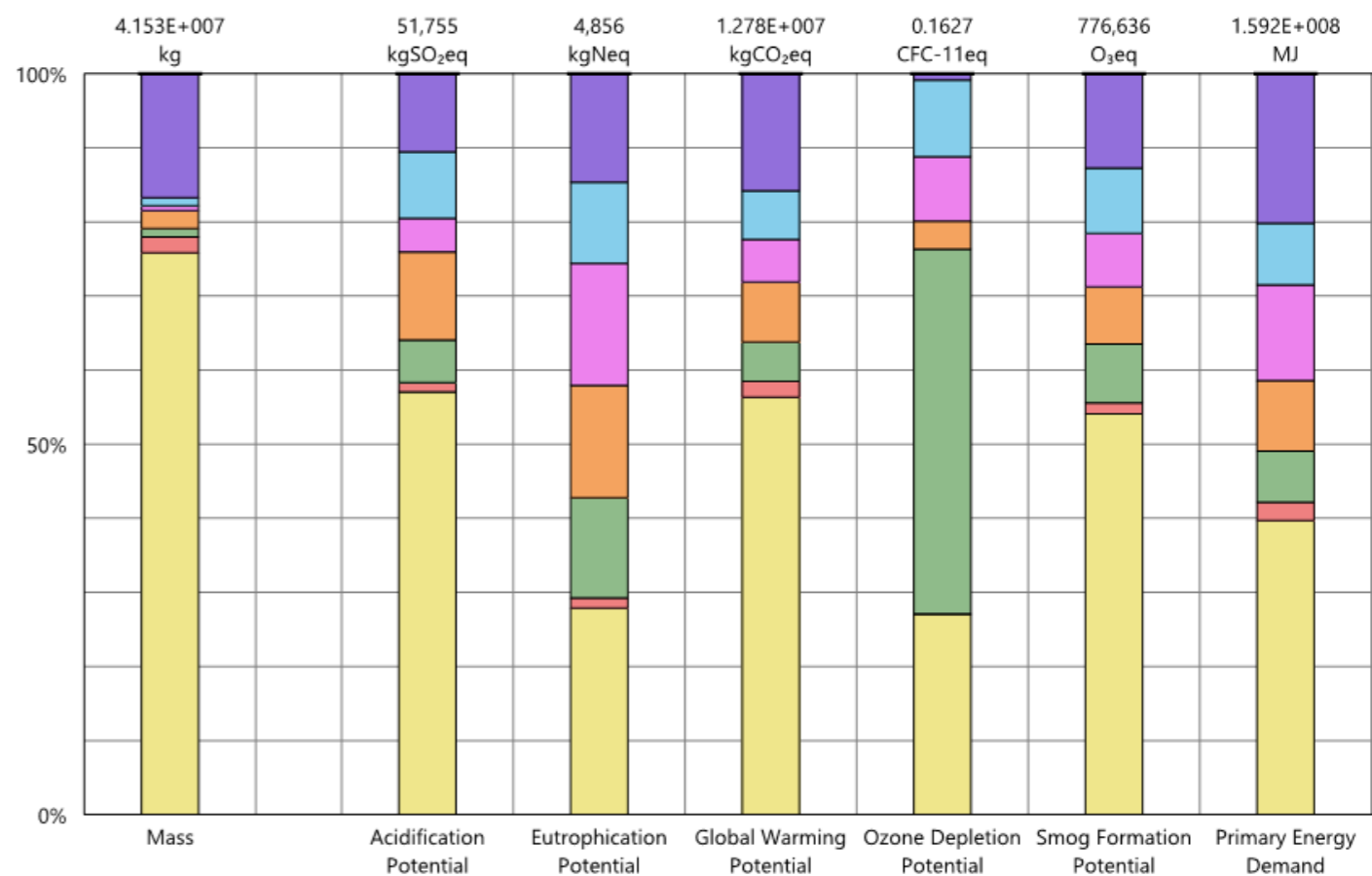

# EARLY-PHASE WHOLE BUILDING LCA



### Global Warming Potential

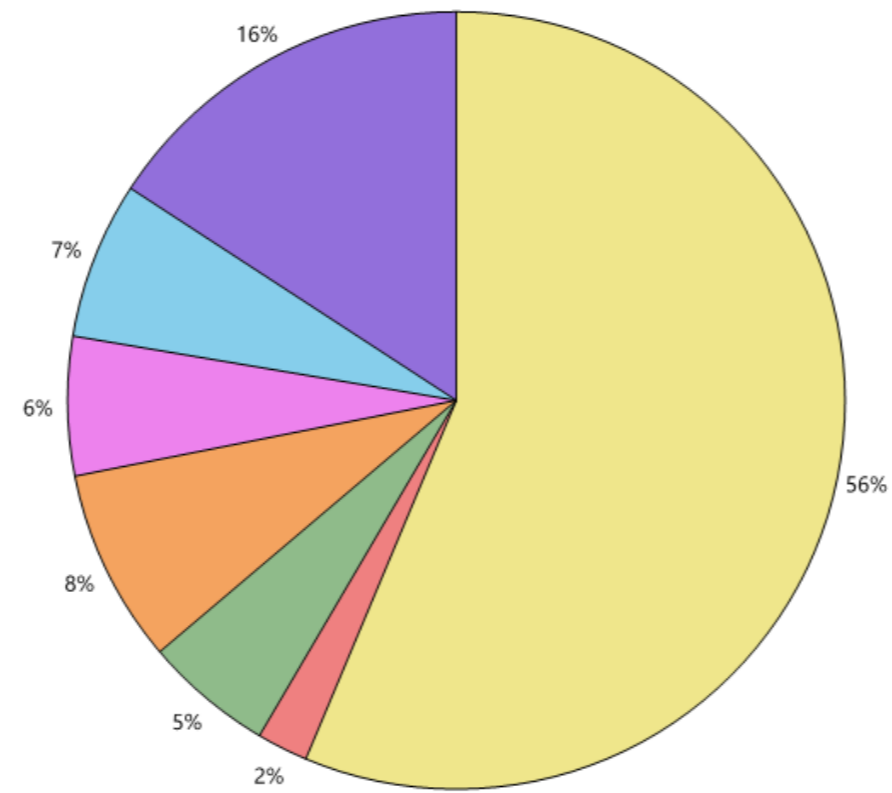

Global Warming Potential

#### 03 - Concrete

- Cast-in-place concrete, reinforced structural concrete, 3000 psi (20 MPa)
- Cast-in-place concrete, reinforced structural concrete, 4000 psi (30 MPa)
- Cast-in-place concrete, reinforced structural concrete, 5000 psi (35 MPa)
- Concrete, unreinforced, 5000 psi (35 MPa), 25% fly ash
- Precast concrete paver
- Reinforced concrete footing, custom
- Stair, cast-in-place concrete
- Stair, concrete with topping slab
- Stair, precast single run (stretcher)

#### 04 - Masonry

- Brick, generic, grouted
- Hollow-core CMU, grouted
- Solid-core CMU, ungrouted

#### 05 - Metals

- Aluminum, extrusion
- Aluminum, sheet
- Stair, steel with concrete fill
- Steel, angle
- Steel, bar
- Steel, channel
- Steel, C-H-stud metal framing
- Steel, C-stud metal framing
- Steel, furring channel
- Steel, hollow structural section
- Steel, plate
- Steel, sheet, carbon steel
- Steel, sheet, perforated
- Steel, U-track section
- Steel, wide flange shape

#### 06 - Wood/Plastics/Composites

- Composite wood I-joist
- Domestic hardwood
- Domestic softwood
- Heavy timber
- Plywood, exterior grade
- Plywood, interior grade
- Stair, hardwood, tread only
- Wood framing
- Wood framing with insulation

#### 07 - Thermal and Moisture Protection

- EPDM sheet, waterproofing
- Expanded polystyrene (EPS), board
- Extruded polystyrene (XPS), board
- Glass-fiber, blanket
- Mineral wool, board, generic
- Polyethylene sheet vapor barrier (HDPE)
- SBS modified bitumen, sheet
- Self adhering membrane

#### 08 - Openings and Glazing

- Aluminum mullion
- Door frame, aluminum
- Door, fire-rated, wood, flush
- Door, interior, glass
- Door, interior, steel
- Door, interior, wood, hollow core, flush
- Door, interior, wood, structural composite core, flush
- Glazing, double pane IGU
- Glazing, monolithic sheet
- Window frame, aluminum
- Window frame, vinyl
- Window frame, wood
- Wood mullion

#### 09 - Finishes

- Acoustic ceiling system, mineral fiber board
- Ceramic tile, glazed
- Flooring, underlayment, cementitious
- Wall board, gypsum

### Results per Tally Entry (Material Assembly)

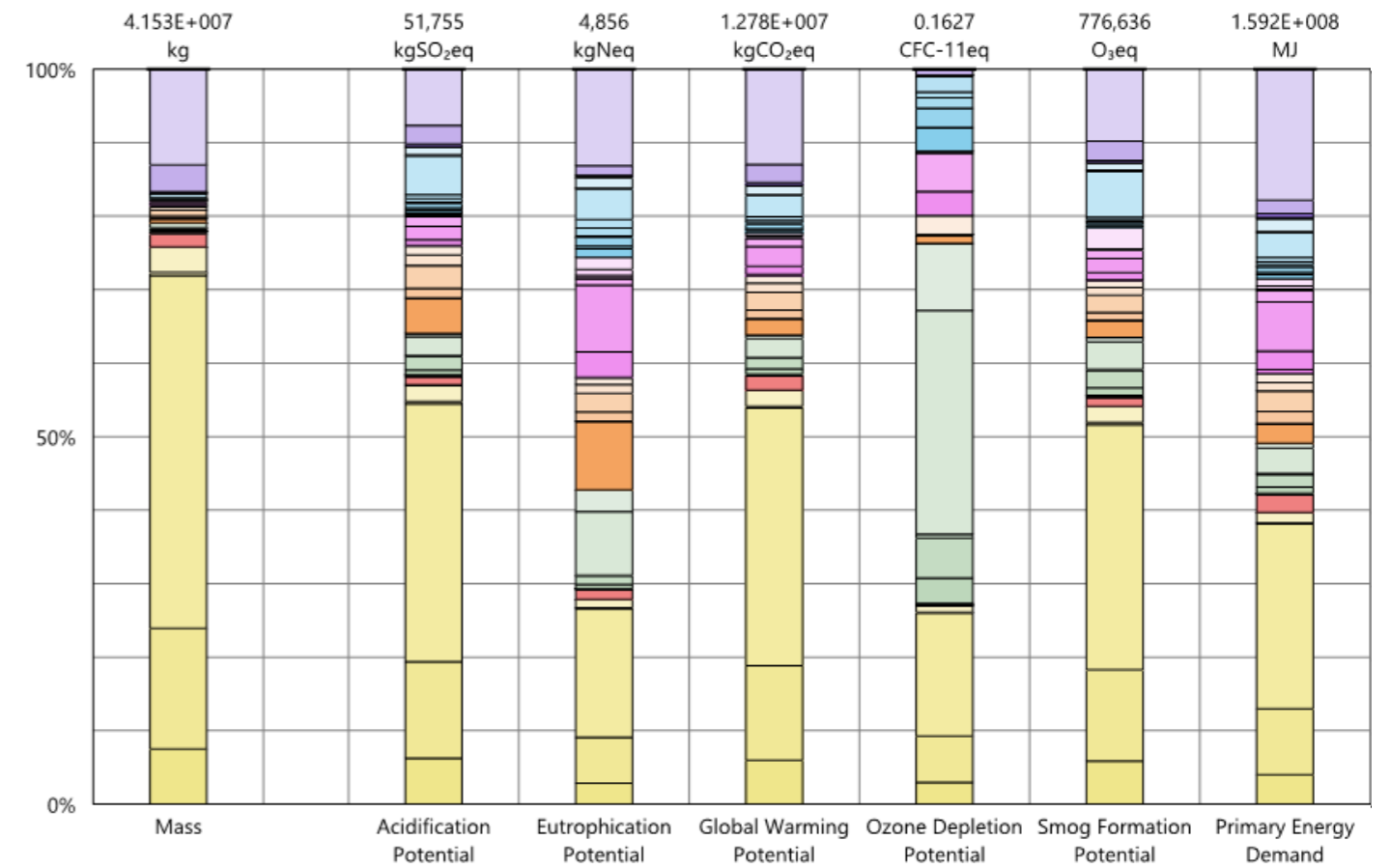

# EARLY-PHASE WHOLE BUILDING LCA

Concrete members

Rain screen panels

Beams

Walls

Floors & stairs

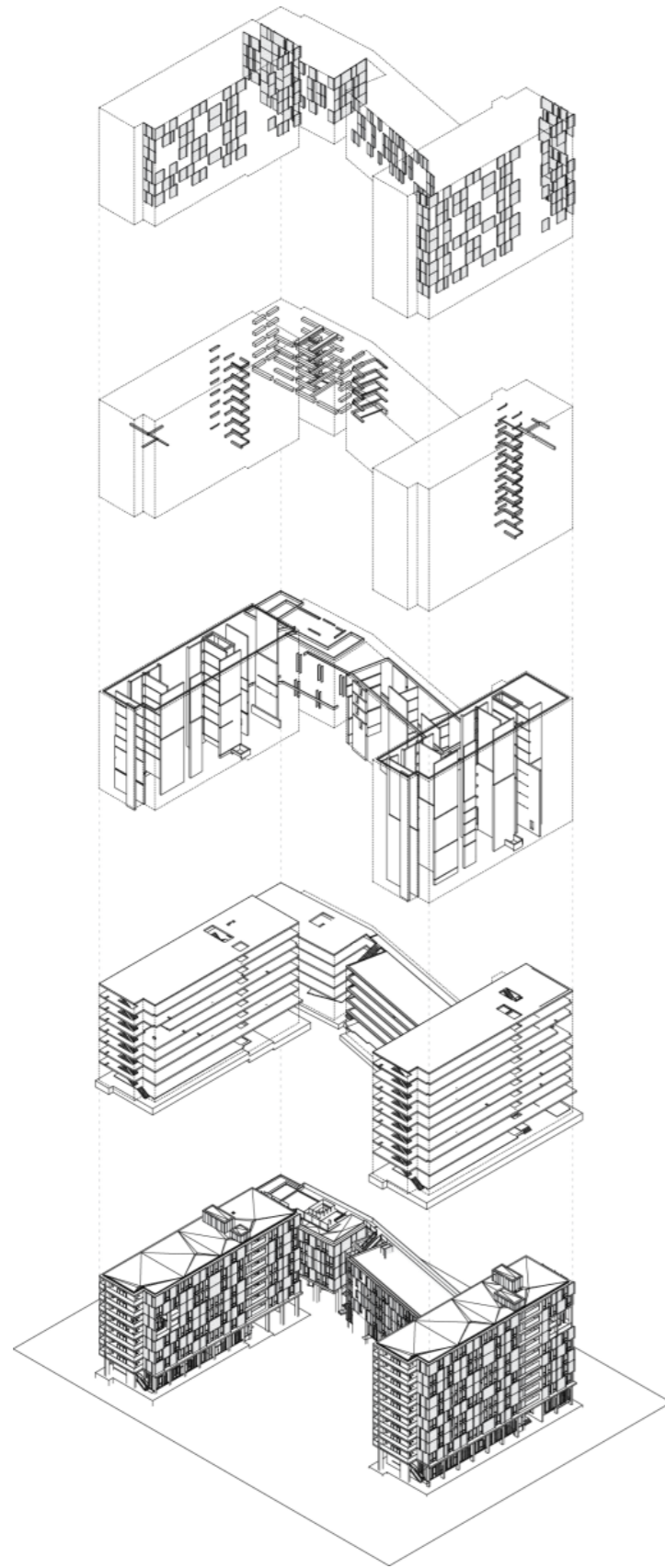

Embodied carbon reductions based on concrete mix

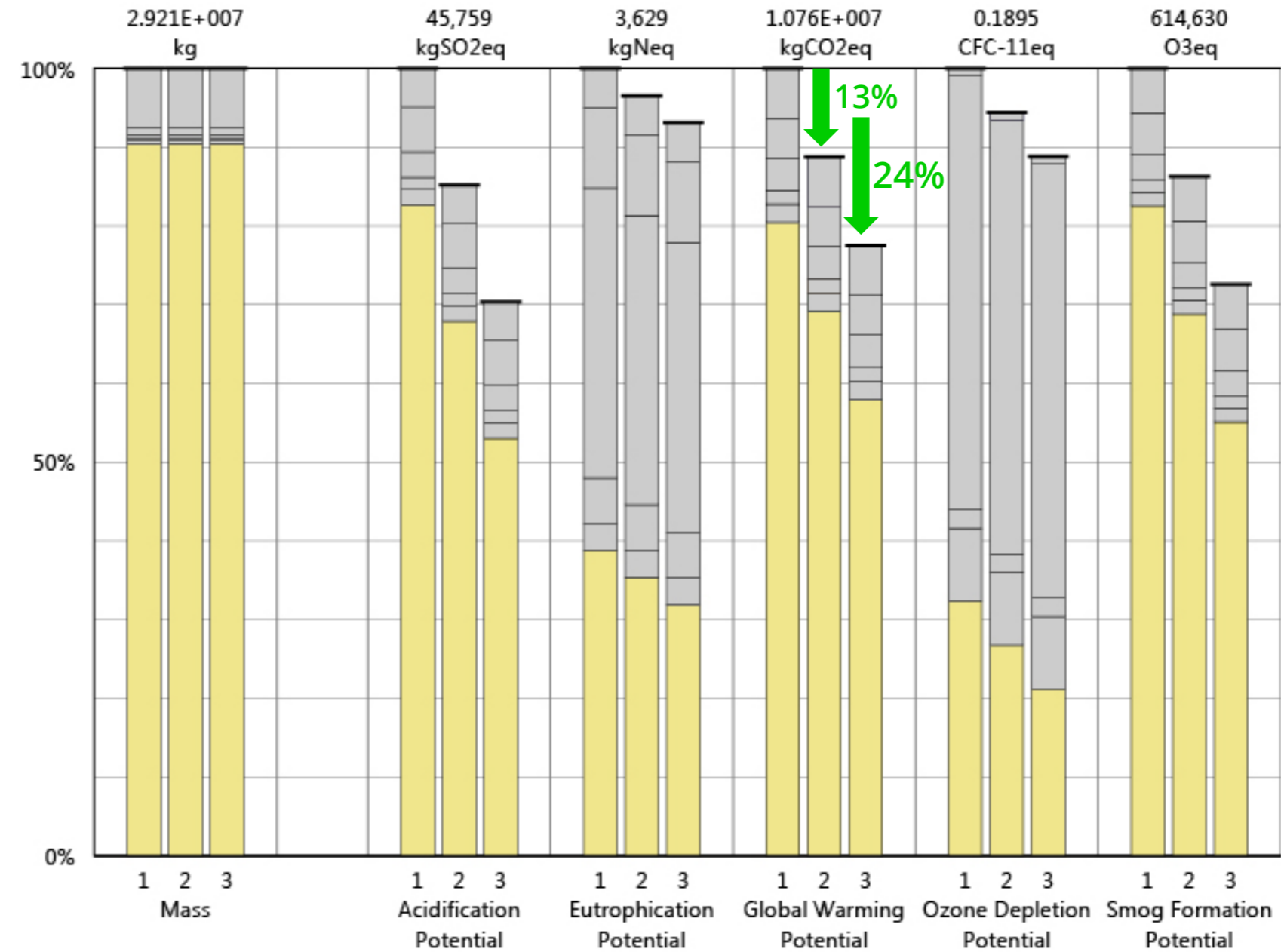

CSI Divisions

- 03 - Concrete
- 05 - Metals
- 06 - Wood/Plastics/Composites
- 07 - Thermal and Moisture Protection
- 08 - Openings and Glazing
- 09 - Finishes

Design Options

- Option 1 - Concrete, 00% Fly Ash
- Option 2 - Concrete, 25% Fly Ash
- Option 3 - Concrete, 50% Fly Ash & extended cure time

EARLY-PHASE WHOLE BUILDING LCA



### Structural Options

- 16" spacing wood framing (baseline)
- 24" spacing wood framing
- Increased SCMs from 25% to 50%

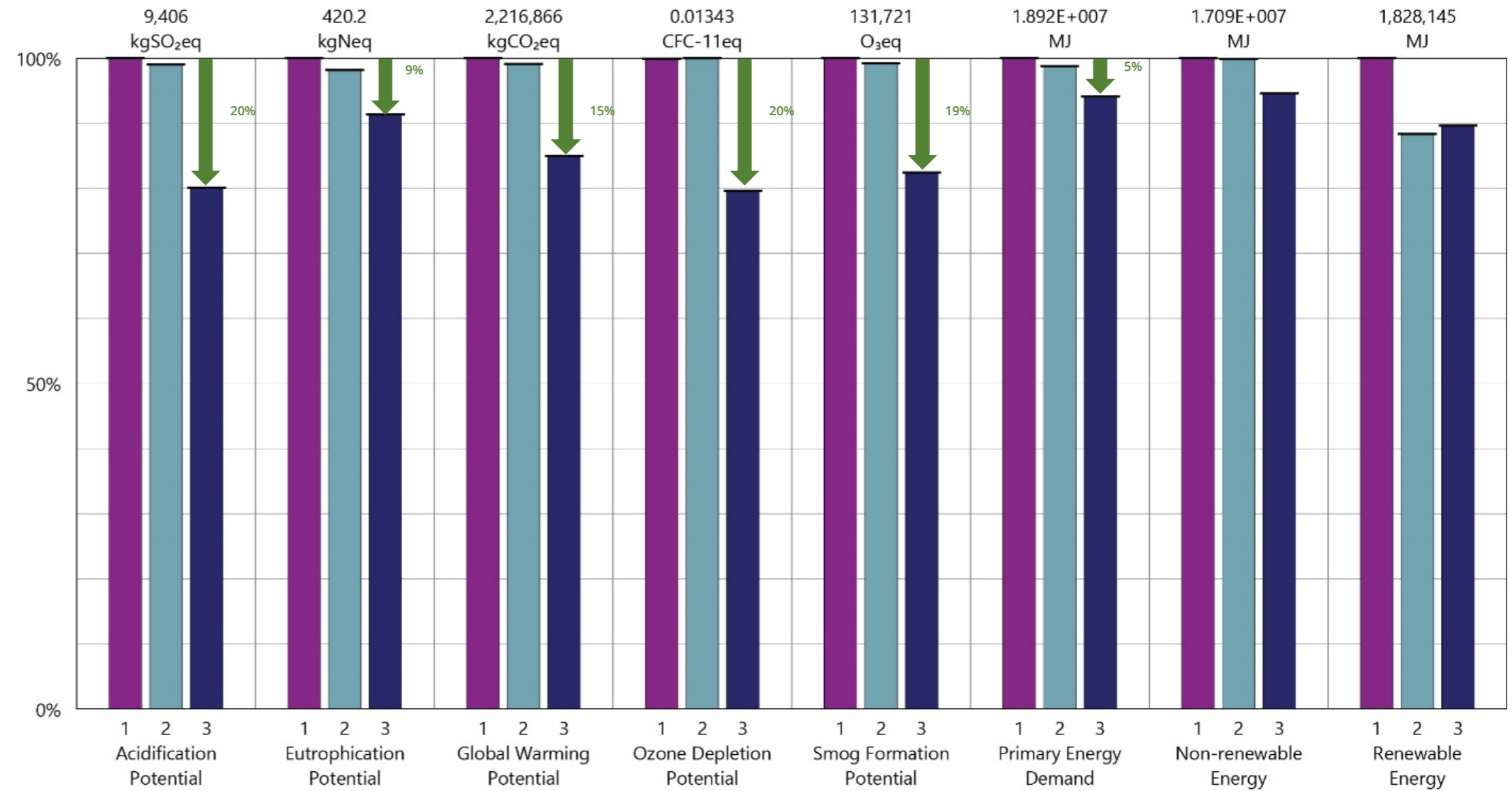

## DESIGN OPTIONS



### Life Cycle Stages

- Manufacturing
- Maintenance and Replacement
- End of Life
- Net value (impacts + credits)

### Design Options

- Option 1 - Brick (primary)
- Option 2 - Conc.



Option 1



Option 2

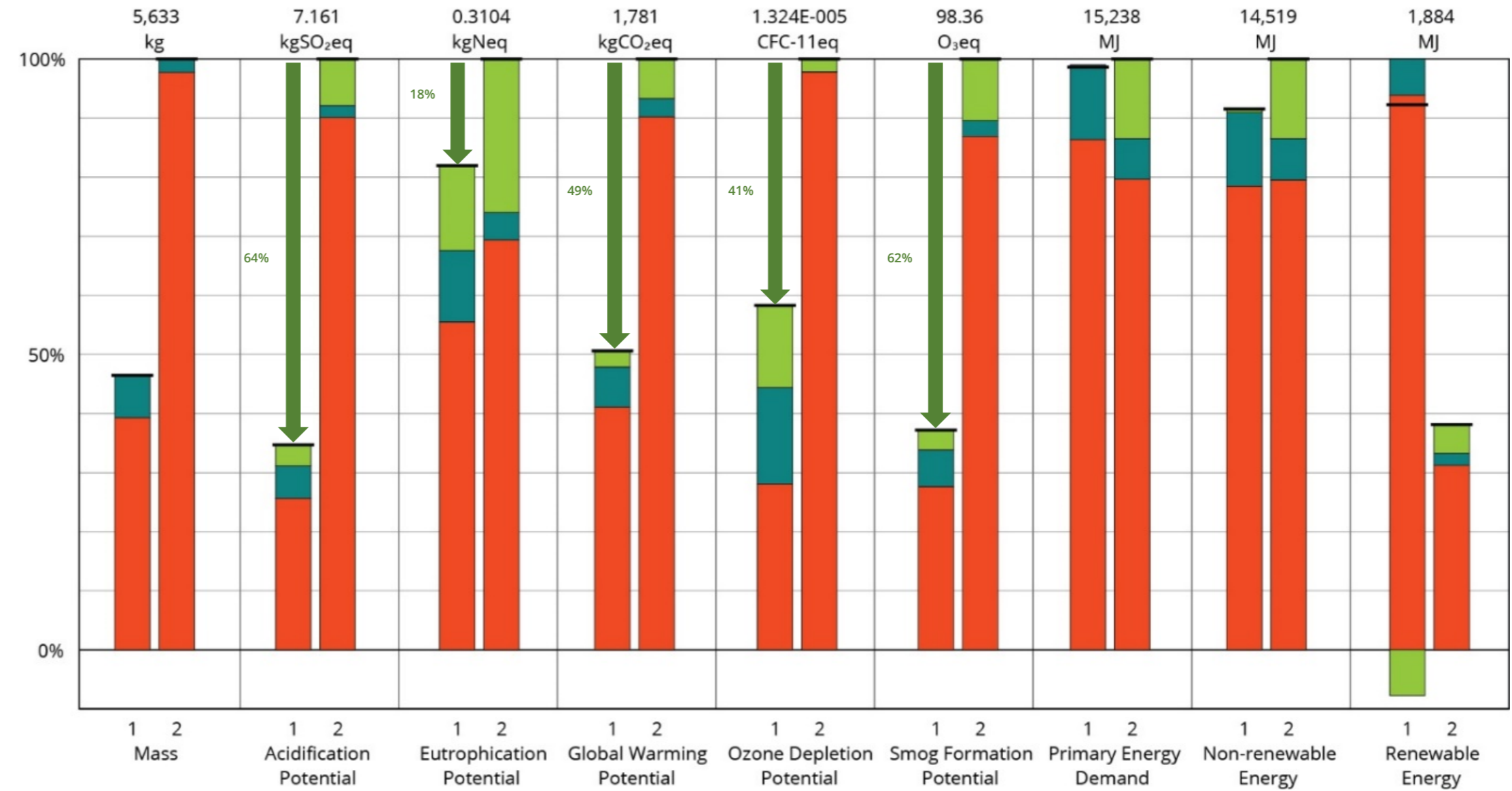

# DESIGN OPTIONS



### Life Cycle Stages

- Manufacturing
- Maintenance and Replacement
- End of Life
- Net value (impacts + credits)

### Design Options

- Option 1 - Brick (primary)
- Option 2 - Conc.



Option 1



Option 2

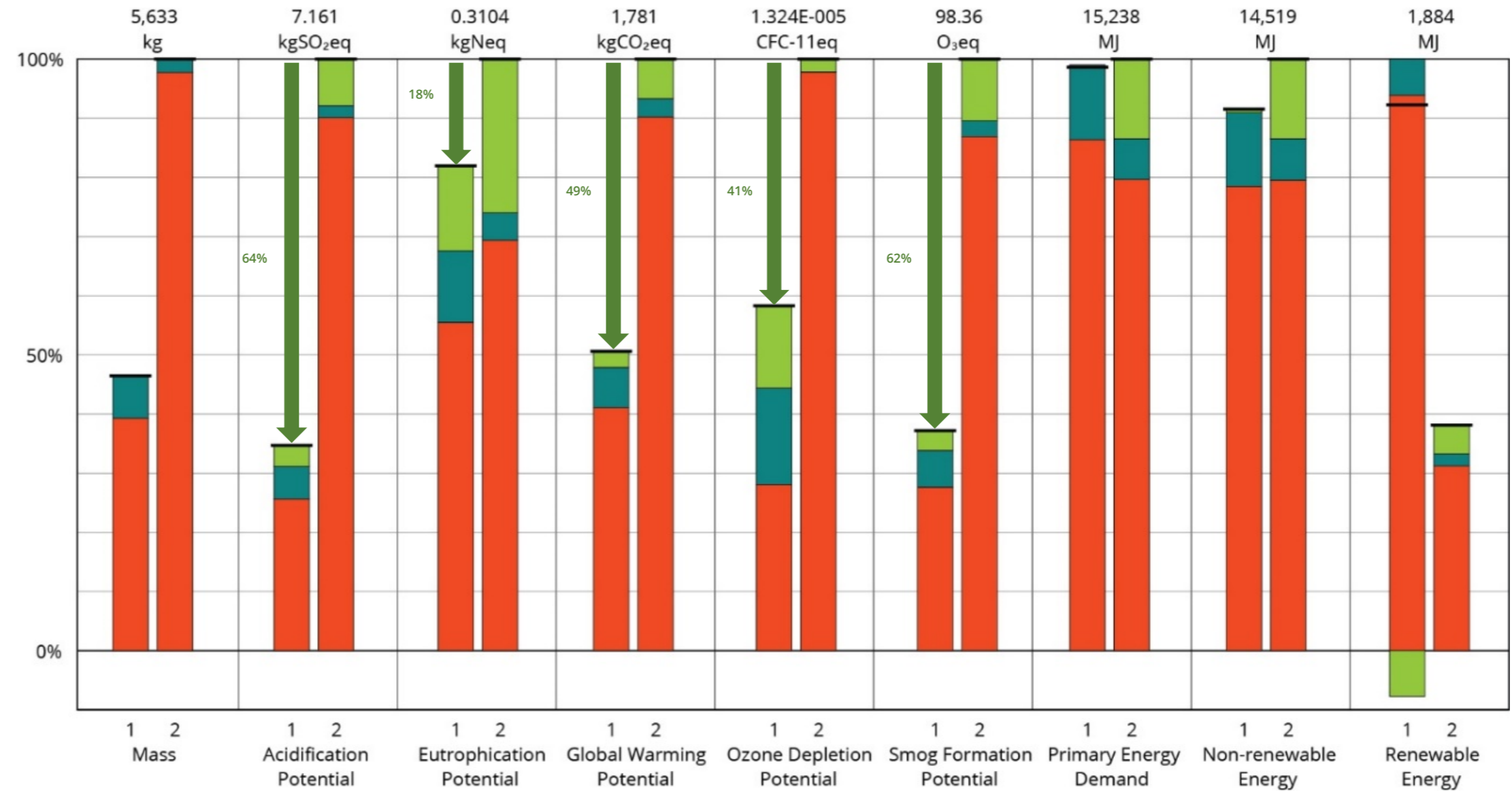

## DESIGN OPTIONS

# Flooring Option Comparison

Amount of material required to produce and maintain 1 ft<sup>2</sup> of flooring in a high traffic setting with consistent acoustical performance for 50 yrs

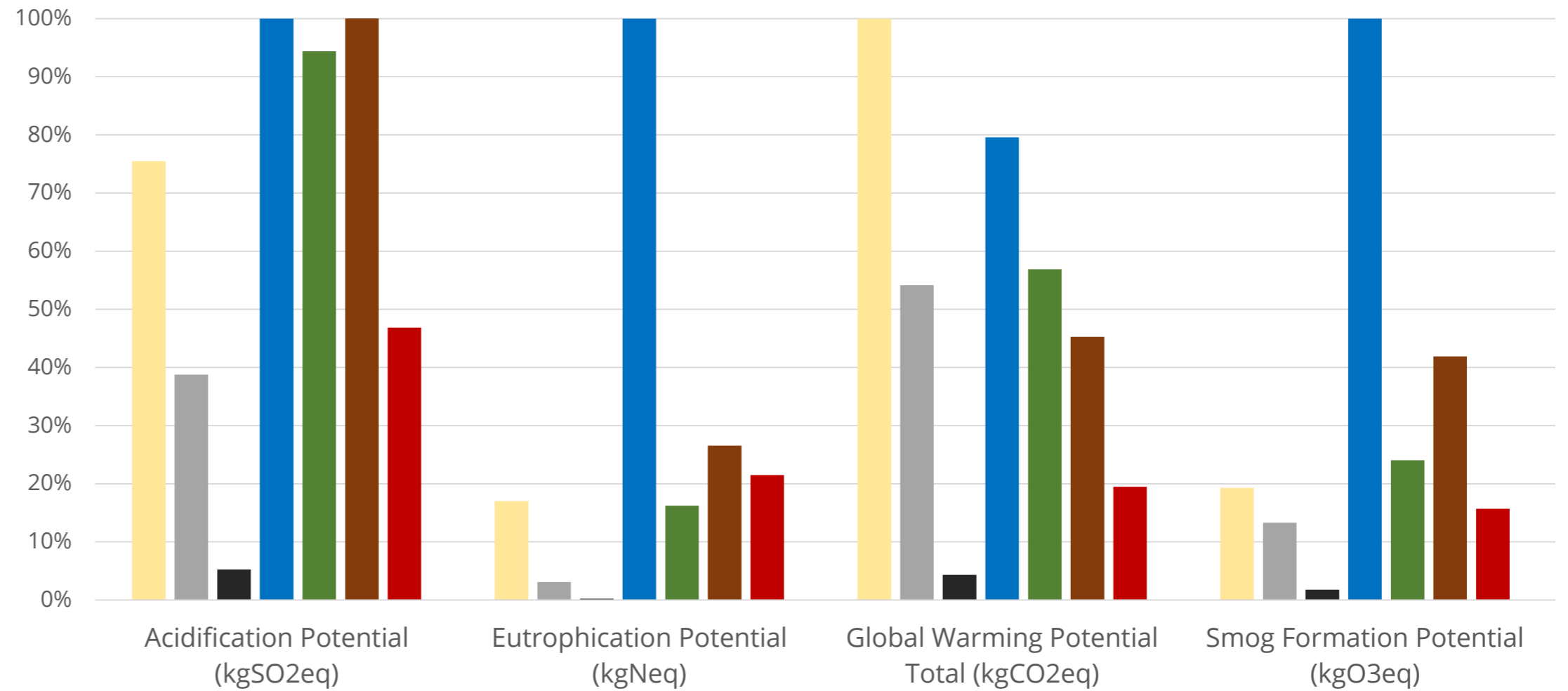
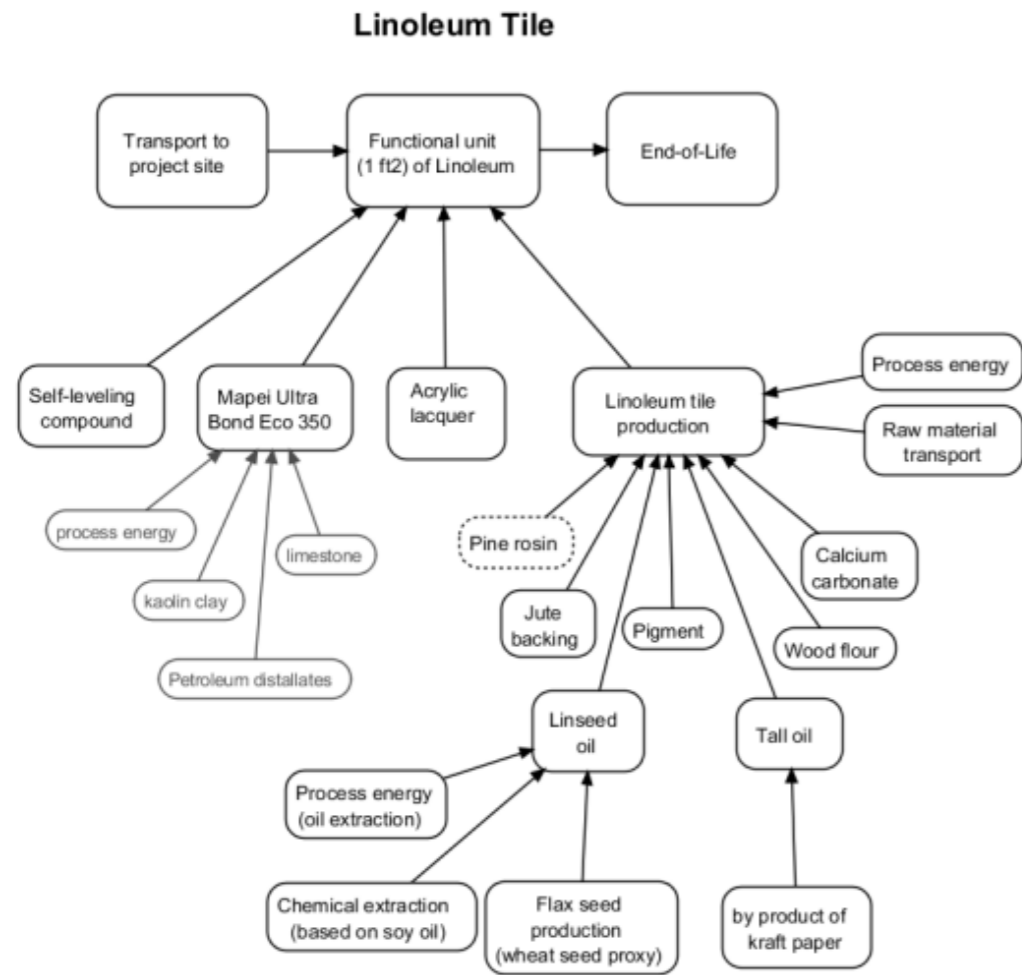

■ Carpet  
 ■ Ceramic Tile  
 ■ Burnished Concrete  
 ■ VCT  
 ■ LVT  
 ■ Rubber  
 ■ Linoleum

CEILING  
EXPOSED CONCRETE

BUILT IN DESK  
WOOD/ PLAM

CEILING/ SOFFIT  
PAINTED GYPSUM

CABINETS  
WOOD / PLAM

COUNTERTOP  
SOLID SURFACE

LIGHTING  
LINEAR FIXTURE



FLOOR  
RUBBER TILE

	Low Environmental Impact *	No Red List Chemicals	Low Maintenance	High Durability**	Installed Cost/SF ***	Unit Flooring: Cost Change from SD ****	Corridor Flooring: Cost Change from SD ****
<b>CARPET TILE</b>	<input type="radio"/>	<input checked="" type="radio"/>	<input type="radio"/> <sup>1</sup>	<input type="radio"/>	<b>\$ 9</b>	<b>N/A</b>	<b>\$ 34,000</b>
<b>CERAMIC TILE</b>	<input checked="" type="radio"/>	<input checked="" type="radio"/>	<input checked="" type="radio"/> <sup>2</sup>	<input checked="" type="radio"/>	<b>\$ 28</b>	<b>N/A</b>	<b>+ \$ 600,000</b>
<b>VINYL COMPOSITION TILE</b>	<input type="radio"/>	<input type="radio"/>	<input type="radio"/> <sup>4</sup>	<input checked="" type="radio"/>	<b>\$ 7</b>	<b>\$ 2,000,000</b>	<b>\$ 100,000</b>
<b>LUXURY VINYL TILE</b>	<input checked="" type="radio"/>	<input type="radio"/>	<input type="radio"/> <sup>5</sup>	<input checked="" type="radio"/>	<b>\$ 10</b>	<b>\$ 1,400,000</b>	<b>---</b>
<b>RUBBER</b>	<input checked="" type="radio"/>	<input checked="" type="radio"/>	<input checked="" type="radio"/> <sup>6</sup>	<input checked="" type="radio"/>	<b>\$ 14</b>	<b>\$ 600,000</b>	<b>+ \$ 140,000</b>
<b>LINOLEUM</b>	<input checked="" type="radio"/>	<input checked="" type="radio"/>	<input type="radio"/> <sup>7</sup>	<input checked="" type="radio"/>	<b>\$ 13</b>	<b>\$ 800,000</b>	<b>+ \$ 100,000</b>

yes  
 moderate  
 no

## DESIGN OPTIONS ASSEMBLIES

	Burnished Concrete	Ceramic Tile	Carpet Tile	VCT	LVT	Rubber	Linoleum
<b>Sizes / Format</b>	Slab	Tile	Tile	Sheet or tile	Plank	Sheet or tile	Sheet or tile
<b>Description</b>	Structural slab with finish coating; no acoustic underlayment	Ceramic tile, mortar; acoustic underlayment	carpet tile; acoustic underlayment	Vinyl composite tile; site applied top coat; acoustic underlayment	Luxury vinyl tile; factory-applied UV cured finish; acoustic underlayment	Natural rubber, no additional coating; acoustic underlayment	Linoleum tile; wax polish; acoustic underlayment
<b>Reference Manufacturer</b>				<i>Armstrong, Shaw</i>	<i>Armstrong, Shaw</i>	<i>Nora Sentico</i>	<i>Forbo, Armstrong</i>
<b>Cost/sf</b>	<b>\$10</b>	<b>\$28*</b>	<b>\$9*</b>	<b>\$7*</b>	<b>\$10*</b>	<b>\$14*</b>	<b>\$13*</b>
<b>FACTOR 1: PROGRAM CAPABILITY</b>	Does not meet code required IIC 50 rating	Bathroom	Hallway Living Area	Hallway Living Area Bathroom	Hallway Living Area Bathroom	Hallway Living Area Bathroom	Hallway Living Area Bathroom
<b>FACTOR 2: ENVIRONMENTAL IMPACT</b> <i>Based on results of Life Cycle Assessment (LCA), draws from multiple impact categories</i>	<b>Very good</b> Makes use of structural material, relies on finishing technique	<b>Poor</b> High carbon footprint due to energy intensive manufacturing	<b>Very poor</b> High environmental impacts due to frequent replacement and energy intensive manufacturing	<b>Very poor</b> Much of impacts connected to coatings, stripper and polish	<b>Poor</b> High levels of vinyl and urethane	<b>Good</b> Made from recycled materials, No Red List Chemicals	<b>Very good</b> Bio-based material, low environmental impact in all categories
<b>FACTOR 3: RED LIST CHEMICALS / TOXICITY</b> <i>Includes chemicals of concern &amp; known carcinogens prohibited by project guidelines</i>	<b>Good</b> No Red List Chemicals, VOC free coatings available	<b>Good</b> No Red List Chemicals, VOC free	<b>Good</b> No Red List Chemicals, VOC free, Some concern for air quality/allergens from dust accumulation	<b>Poor</b> Contains phthalates, a Red List Chemical; coatings may pose VOC concerns	<b>Poor</b> Contains high levels of phthalates, a Red List Chemical; coatings may pose VOC concerns	<b>Good</b> No Red List Chemicals, VOC free	<b>Good</b> No Red List Chemicals, VOC free
<b>FACTOR 4: DURABILITY</b> <i>Approximate life span based on manufacturer warrantee and Environmental Product Declaration (EPD)</i>	<b>Very good</b> Full life of building, structural element	<b>Very good</b> 30 year life span; Difficult to replace broken tile	<b>Poor</b> 10 year life span; Damaged tiles can be easily replaced	<b>Poor</b> 15-20 year life span; Damaged tiles can be easily replaced	<b>Good</b> 20 year life span; More durable than VCT, resistant to divots; Damaged planks can be easily replaced	<b>Very good</b> 30 year life span; Damaged tiles can be easily replaced; Indentations occur, but rebound	<b>Good</b> 30 year life span; Damaged tiles can be easily replaced; Indentations occur, but rebound
<b>FACTOR 5: MAINTENANCE</b> <i>Required and recommended maintenance practices</i>	<b>Low</b> None	<b>Low</b> No refinished required; potential discoloration of grout over time.	<b>Medium</b> Requires vacuuming and Regular deep cleaning in high traffic areas.	<b>High</b> Regular stripping, buffing and recoating (urethane) 1-2 x/year; Required for durability.	<b>Medium</b> Does not require stripping and recoating, buffing and polish; Recommended for aesthetics.	<b>Low</b> No recoating required	<b>Medium</b> Periodic recoating (wet mop/wax, no stripping); Recommended for aesthetics/shine.
<b>FACTOR 6: LIFE CYCLE COST</b> <i>Tracked across 60 years cost/sq ft* material replacement (approx. maintenance cost, if relevant)</i>	<b>\$10</b>	<b>\$56</b>	<b>\$54</b>	<b>\$28</b> (\$1/SqFt/yr maintenance)	<b>\$30</b> (\$1/SqFt /yr maintenance)	<b>\$28</b>	<b>\$26</b> (\$1.50/Sq Ft/yr maintenance)
						* Includes 5mm acoustic underlayment @ \$3/SqFt (will likely be necessary to meet code required IIC rating)	



## ENVIRONMENTAL BENEFIT OF ADAPTIVE REUSE (Removing Module A)

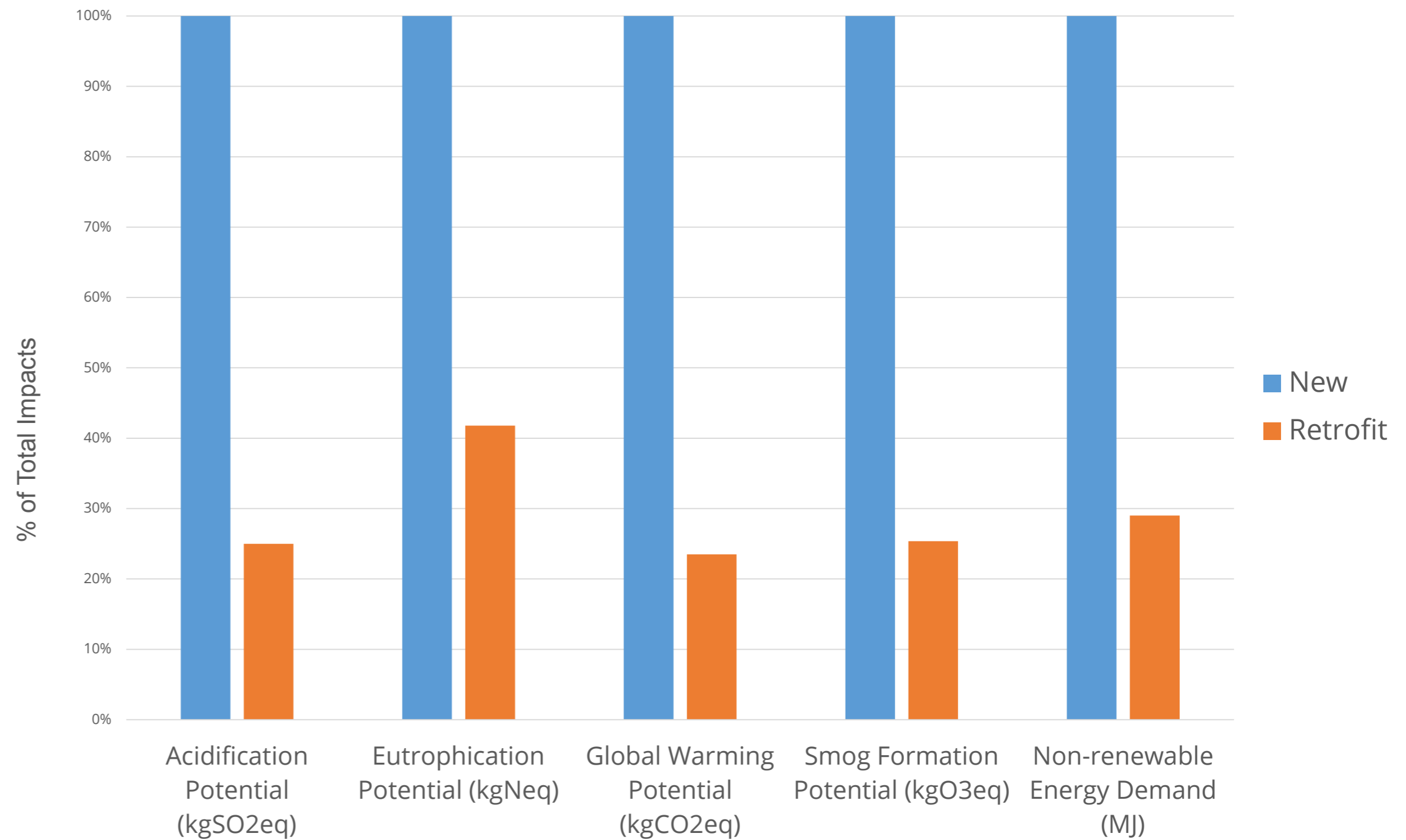

## BENCHMARKING

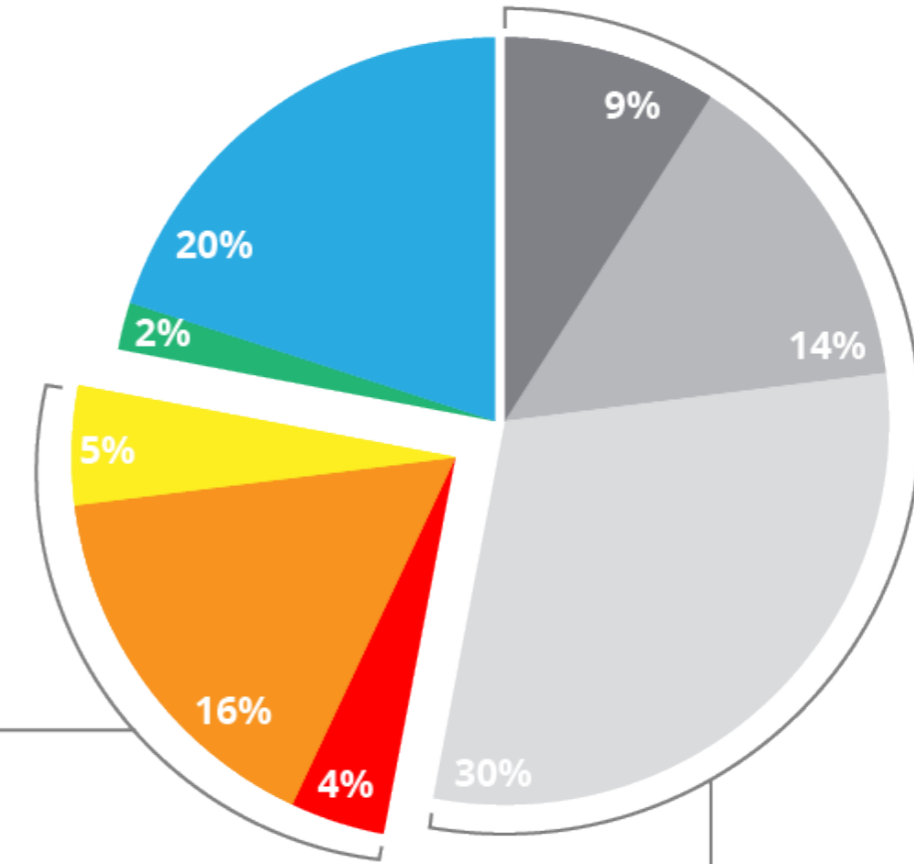
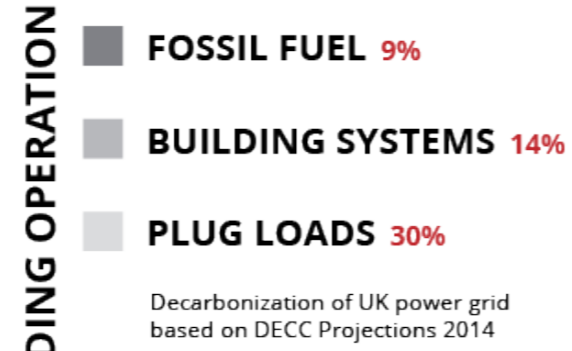
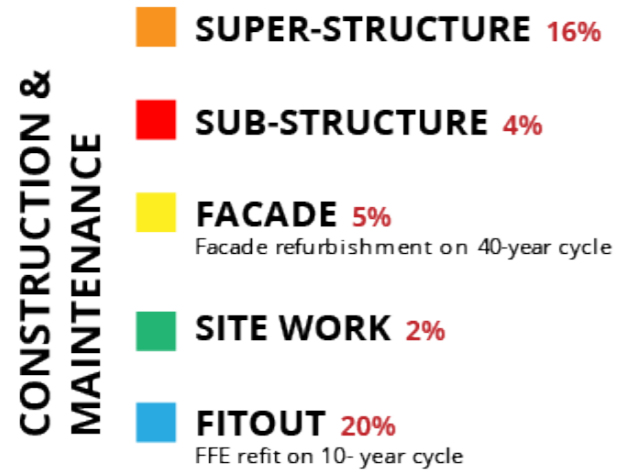

**FACADE & STRUCTURE**  
**25%** of building life-cycle carbon footprint  
**53%** of construction carbon footprint

**BUILDING OPERATION**  
**53%** of building life-cycle carbon footprint

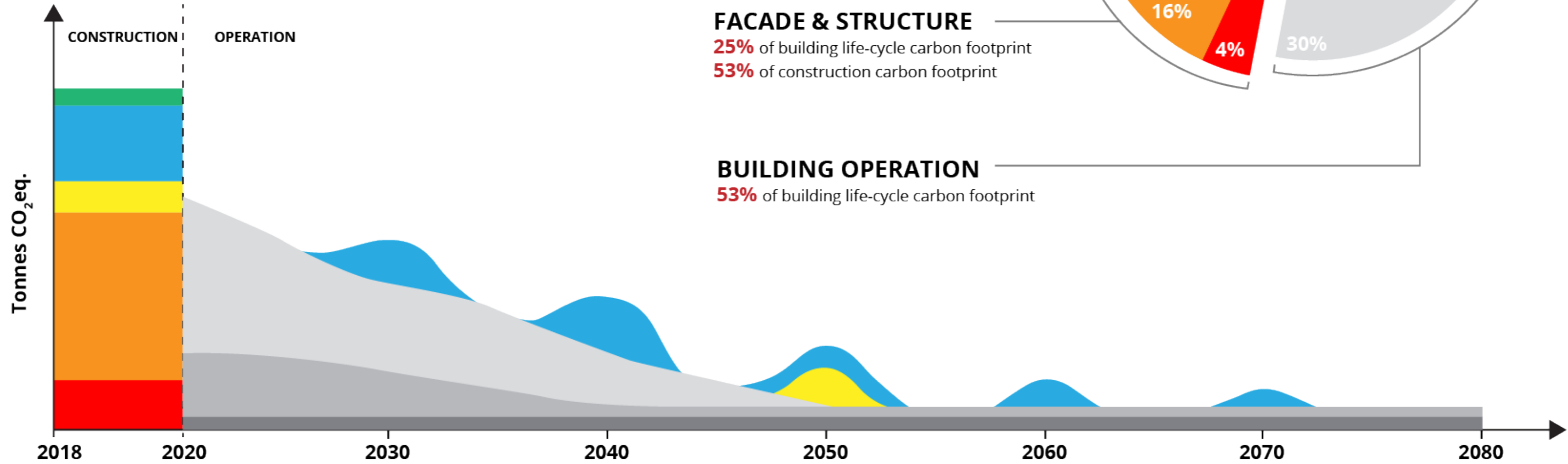

Life cycle carbon study conducted by Ed Sauven, Buro Happold

# BENCHMARKING

# Performance Criteria

# Modeling & Simulation

# Design Decisions

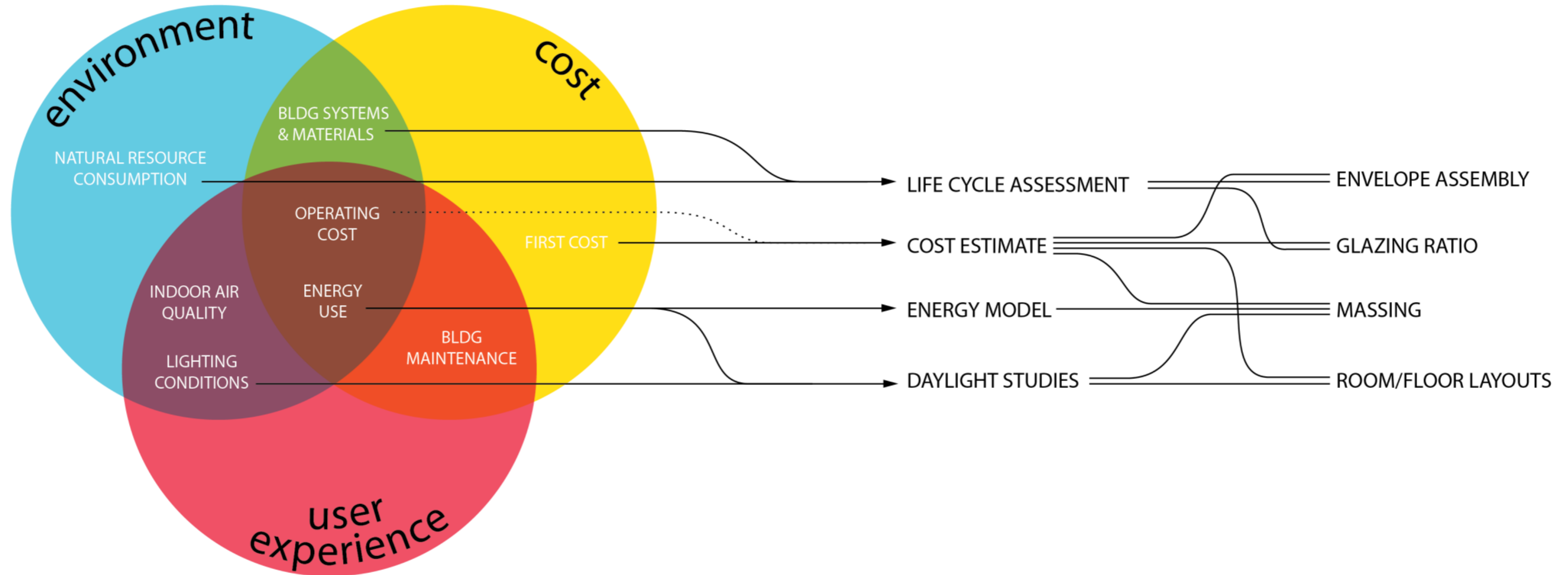

## EXPRESSING VALUES

- 1. SET INTERNAL TARGETS**
- 2. DON'T STOP WITH THE MODEL**
- 3. MAYBE YOU DON'T NEED PERMISSION...**
- 4. BRING MODEL RESULTS TO DESIGN REVIEWS**
- 5. COMPARE OPERATIONAL AND EMBODIED CARBON**

# EMBODIED CARBON IN BUILDINGS



# EMBODIED CARBON IN BUILDINGS

## Session 3: Design Decisions

**Mark D. Webster, PE, LEED AP BD+C**  
Structural Engineering  
31 May 2019

SIMPSON GUMPERTZ & HEGER

Engineering of Structures  
and Building Enclosures



# Embodied Carbon and Structural Materials

- When it comes to addressing embodied carbon, structural materials are a prime target.

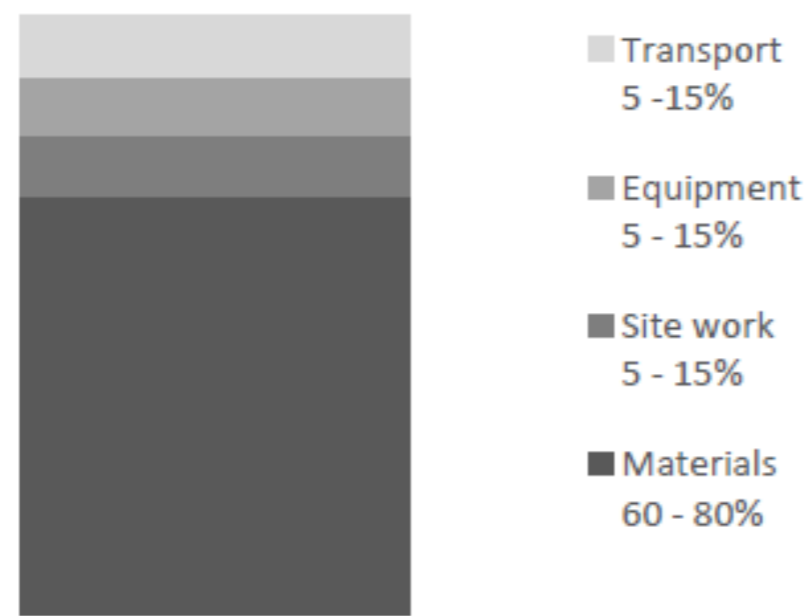

**Figure 4. Where's the Carbon?**

Source: Embodied Carbon Benchmark Project, and review of multiple embodied energy and carbon studies

Source: CLF "Time Value of Carbon" (2017)

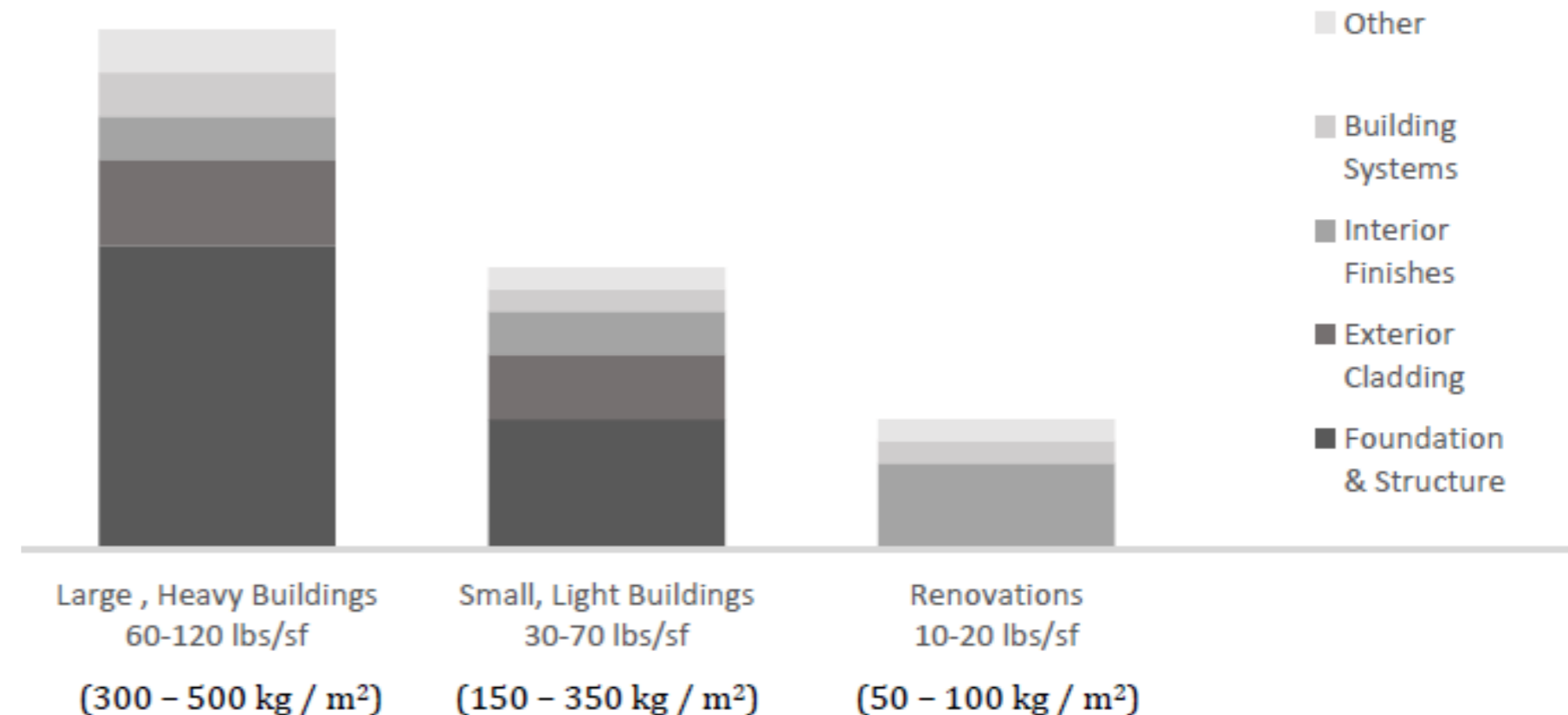

**Figure 5. Carbon Emissions by Building Type and Building Element**

Source: Embodied Carbon Benchmark Project, Carbon Leadership Forum, and review of multiple embodied energy and carbon studies

# Embodied Carbon and Structural Materials

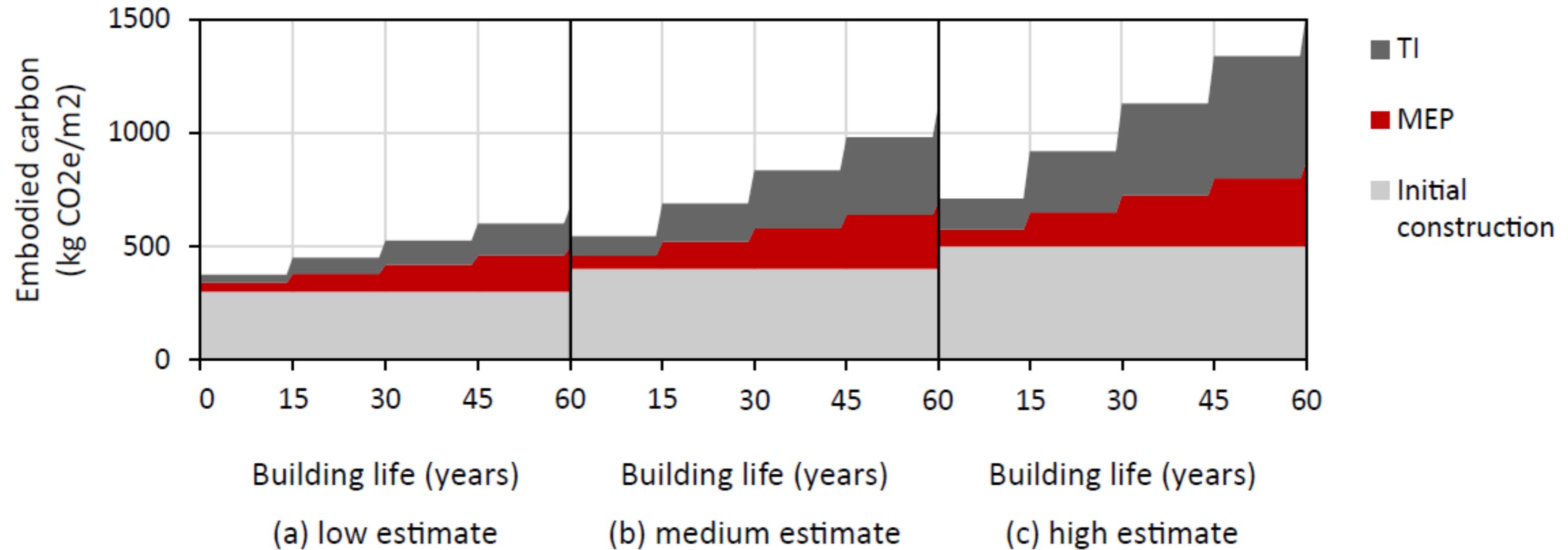
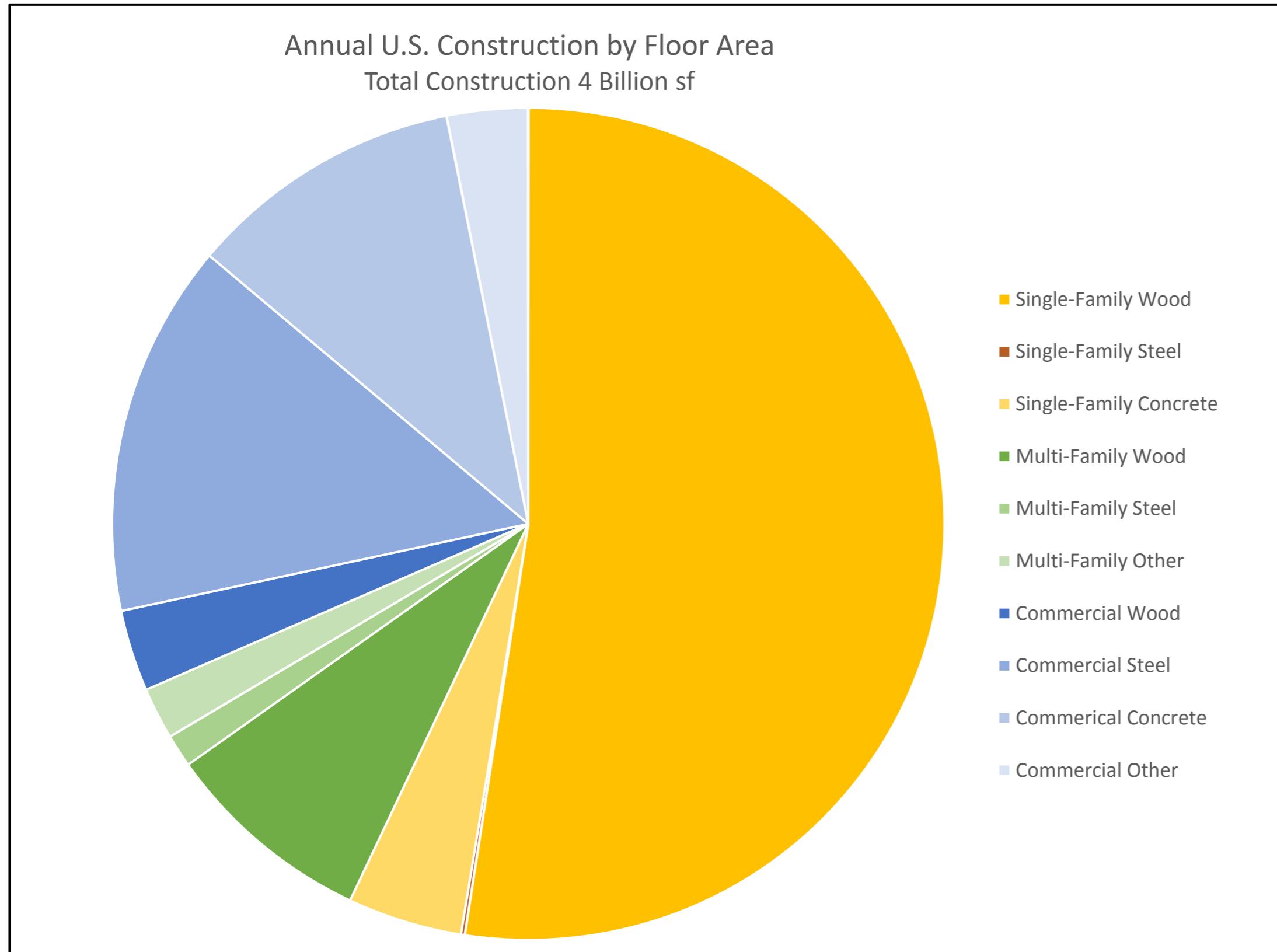

Figure 4. Cumulative embodied carbon impacts of initial construction, MEP, TI, and use (operational) at low, medium, and high estimate levels over 60 years.

Source: CLF “Estimates of Embodied Carbon for Mechanical, Electrical, Plumbing and Tenant Improvements” (2019)

# Where is the Embodied Carbon?



**WORK IN PROGRESS,  
SUBJECT TO REVISION**

Source: SEI Sustainability Committee Carbon Working Group  
Work in Progress

# Where is the Structural Embodied Carbon?

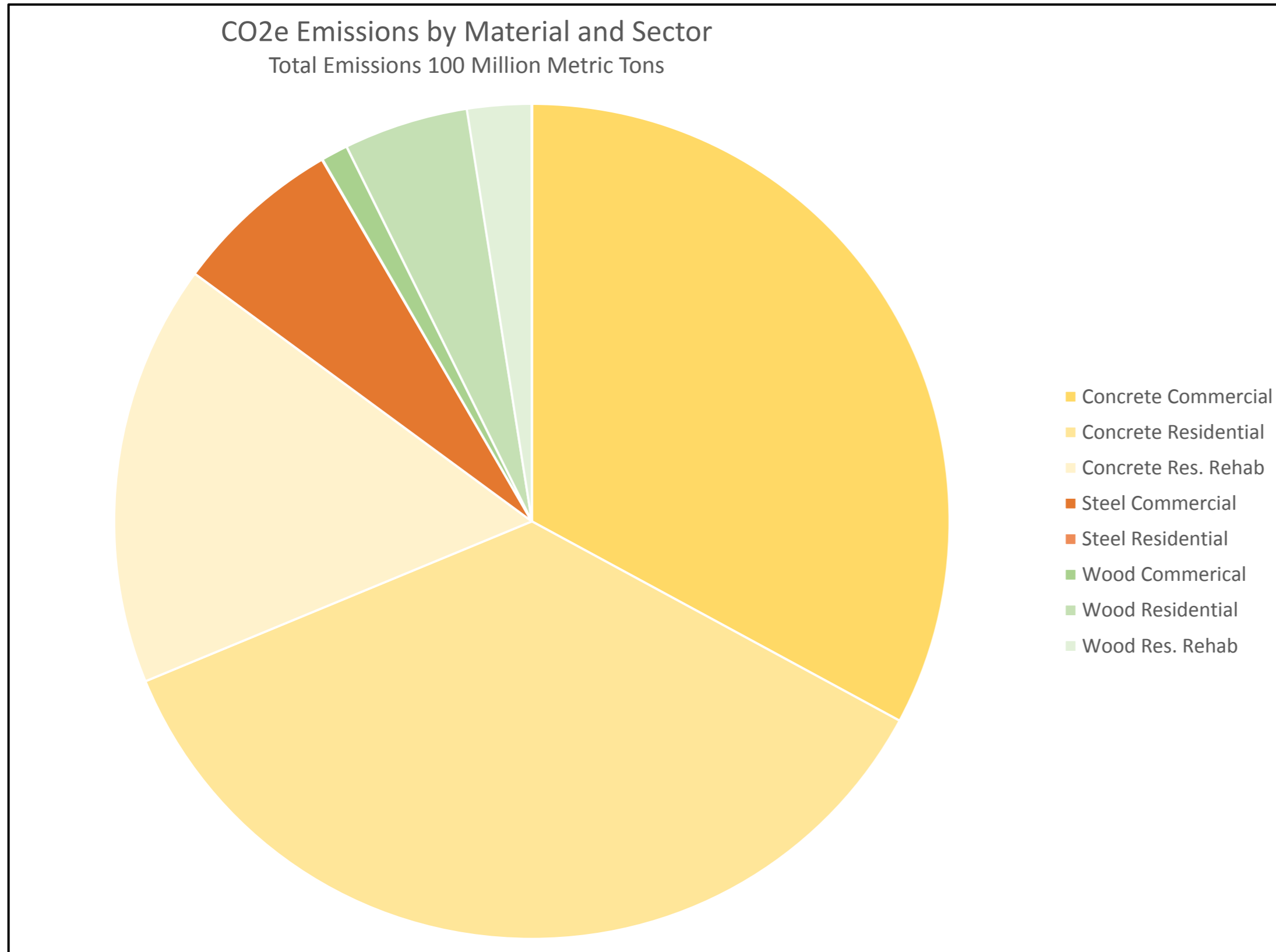

- Concrete, structural steel, and lumber only.
- Excludes rebar and precast concrete.
- Concrete dominates.
- Residential must be addressed.

**WORK IN PROGRESS,  
SUBJECT TO REVISION**

Source: SEI Sustainability Committee Carbon Working Group  
Work in Progress

# Getting to Zero Embodied Carbon by 2050

Path ID	Design	Renewable Electricity	Material Production	Offsets
Maximum Design	40%	15%	10%	35%
Maximum Electricity	20%	30%	10%	40%
Status Quo	10%	5%	10%	75%

**WORK IN PROGRESS,  
SUBJECT TO REVISION**

Source: SEI Sustainability Committee Carbon Working Group  
Work in Progress

# Getting to Zero Embodied Carbon by 2050

## How can we make this happen?

- Learn where the embodied carbon lies and how to reduce it.
- Bring embodied carbon into the conversation from project inception through construction.
  - Architects: Ask structural engineers how to reduce embodied carbon in structure.
  - Structural Engineers: Offer reduction strategies to clients.
- Track embodied carbon in projects.
- CLF and SEI are working together on the SE2050 Initiative to engage structural engineers in tracking and reducing the embodied carbon in building structure.

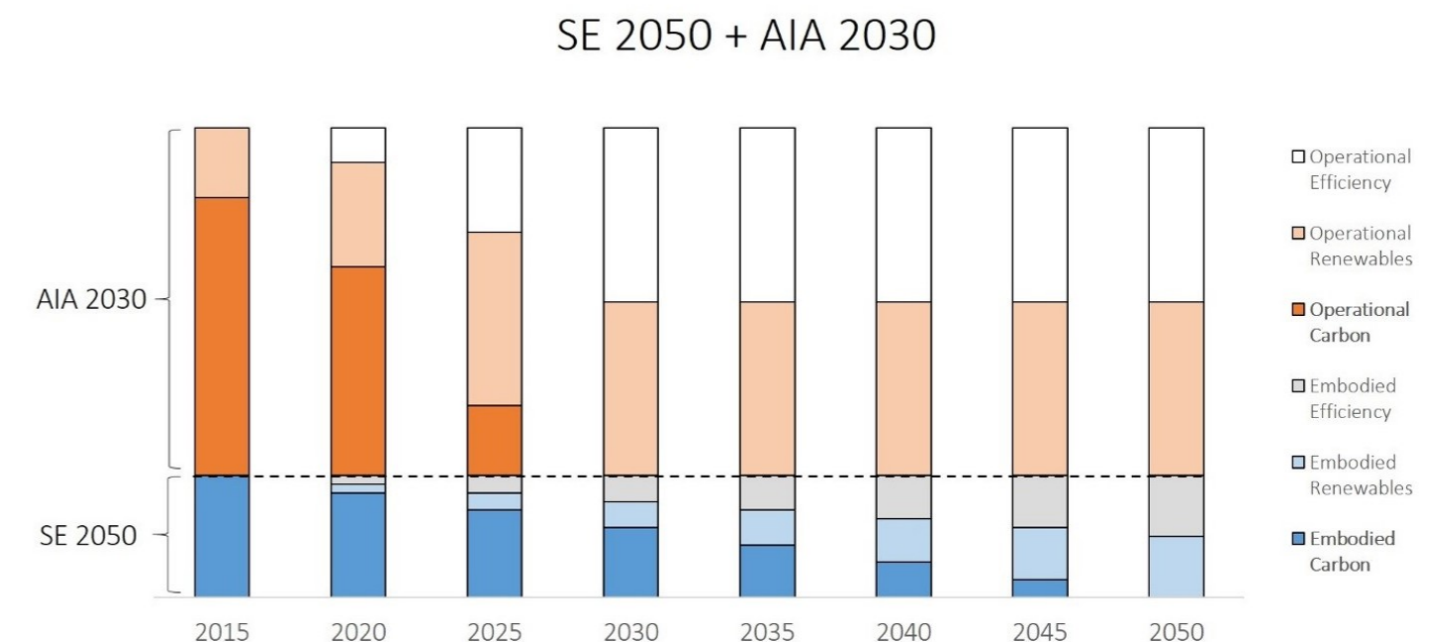

# In-House Research

Note:

XST = no upgrade to existing building

SER = standard energy retrofit

DER = deep energy retrofit

ZEB = new near-zero energy building

env. only = envelope upgrade only

imp. equip. = envelope + equipment upgrade

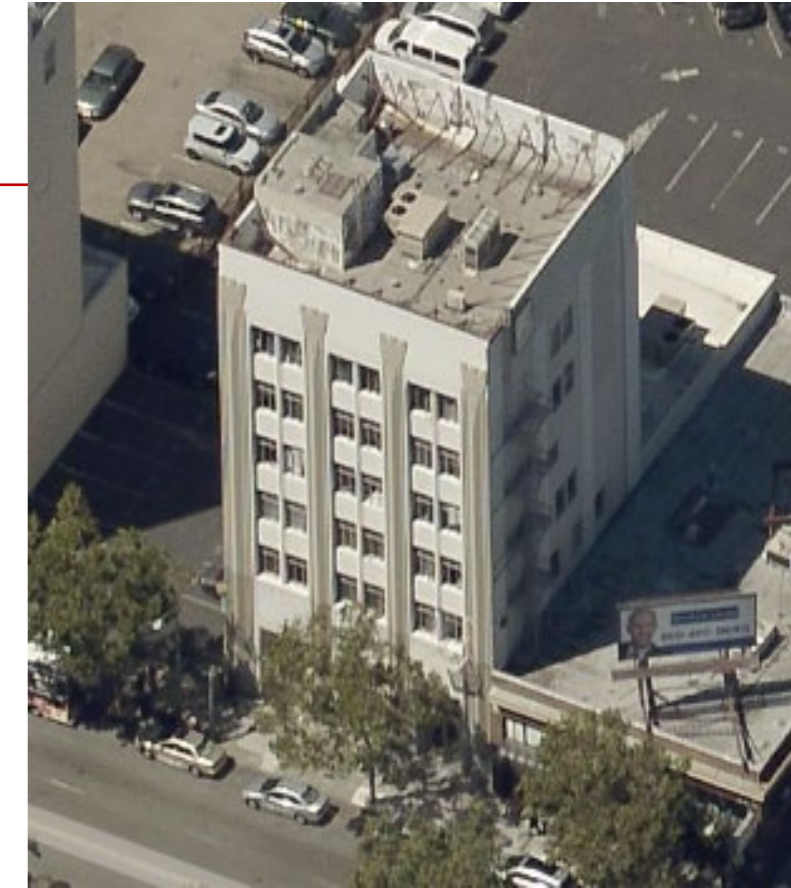

**GWP (20-Year Life Cycle)**

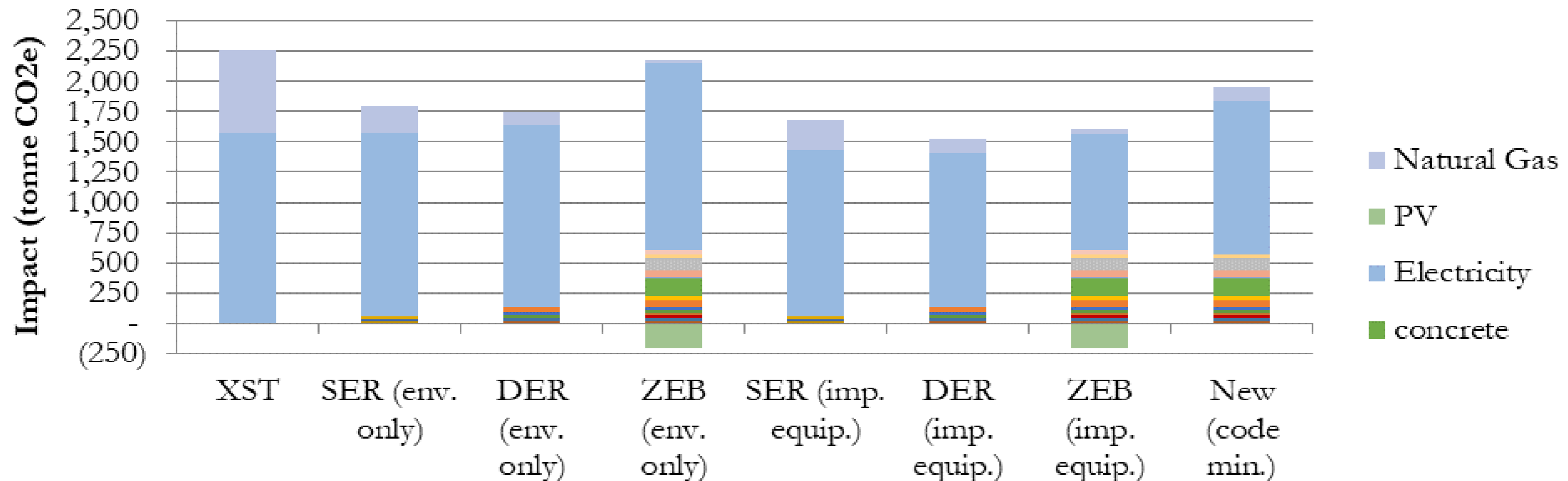

# In-House Research

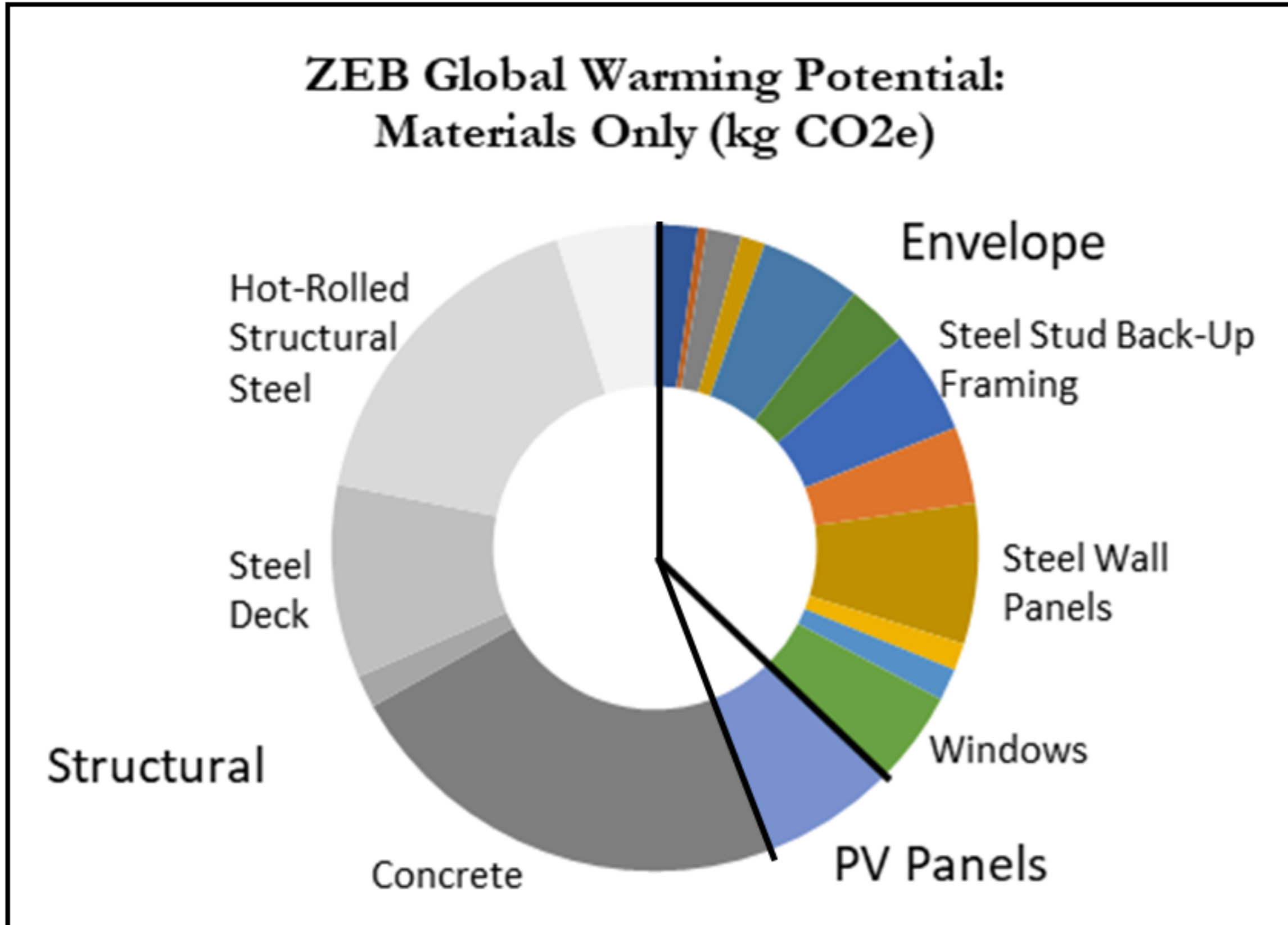

---

**Thank You**  
**mdwebster@sgh.com**

# EMBODIED CARBON IN BUILDINGS





**SKANSKA**

**Reducing the Carbon Footprint of Every Building.**



**WHY do carbon emissions  
matter... to SKANSKA???**

Over the next 35 years,

**two trillion ft<sup>2</sup>**

of new and rebuilt buildings  
will be constructed in cities worldwide.



An entire New York City  
**every 35 days**

for 35 years!





## Embodied Carbon

Manufacture, transport and installation of construction materials

## Operational Carbon

Building Energy Consumption





## Total Carbon Emissions of **Single Building** *Global Average Building Carbon Footprint: Business as Usual*

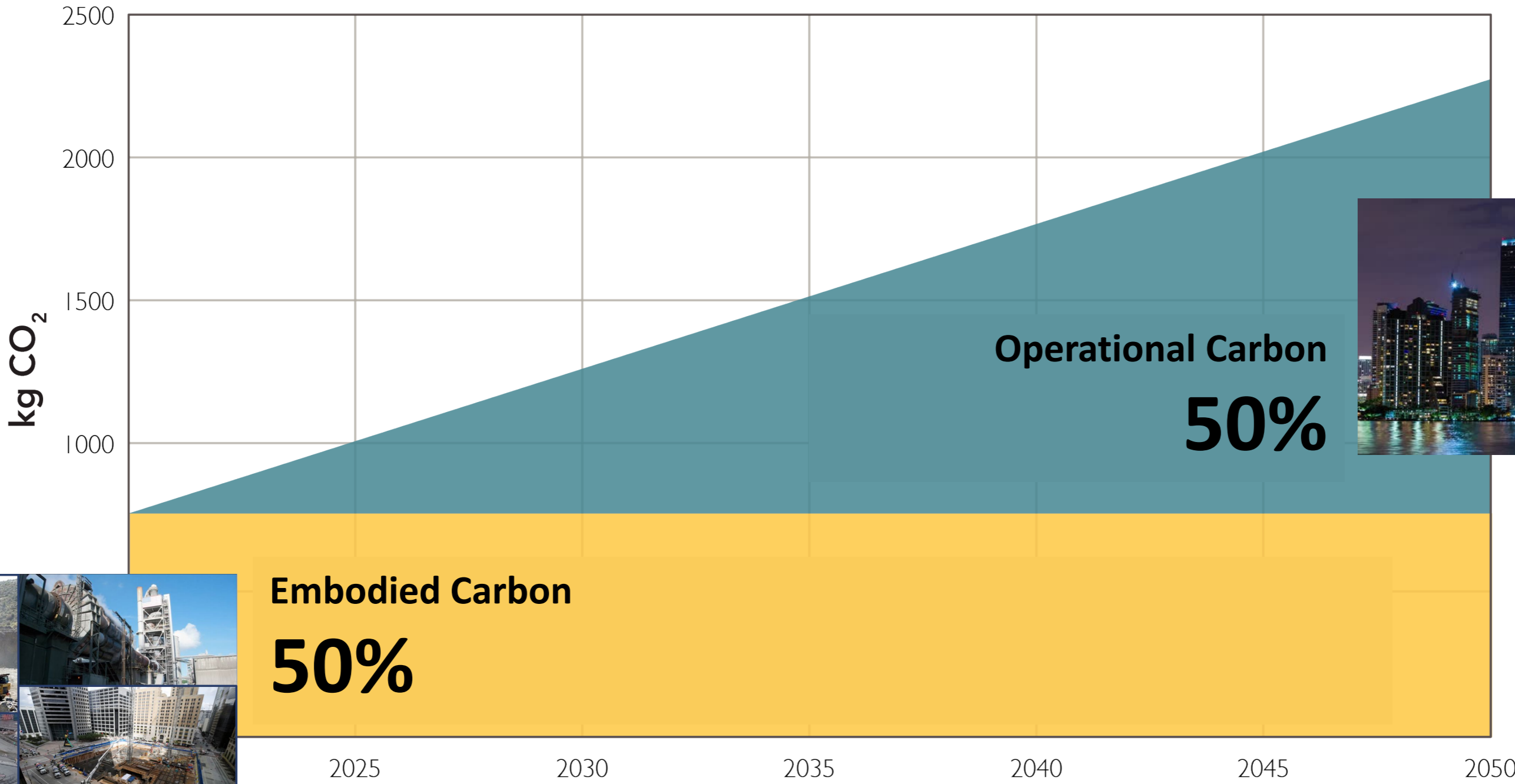

**Embodied Carbon**  
**50%**

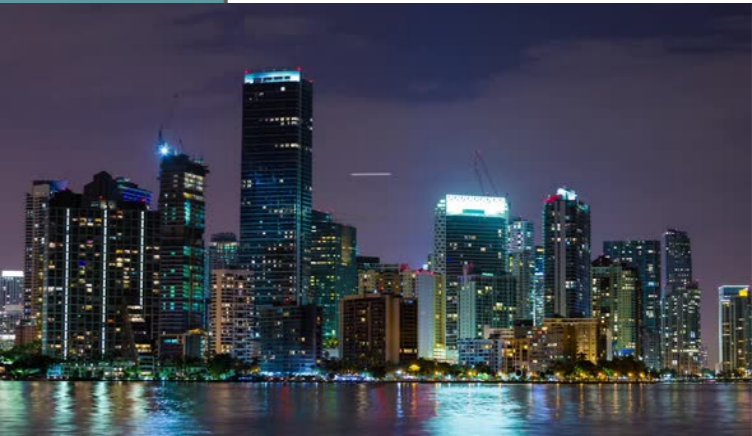

**Operational Carbon**  
**50%**

© 2018 2030, Inc. / Architecture 2030. All Rights Reserved. Data Sources: UN Environment Global Status Report 2017; EIA International Energy Outlook 2017





## Embodied Carbon Benchmarking Study

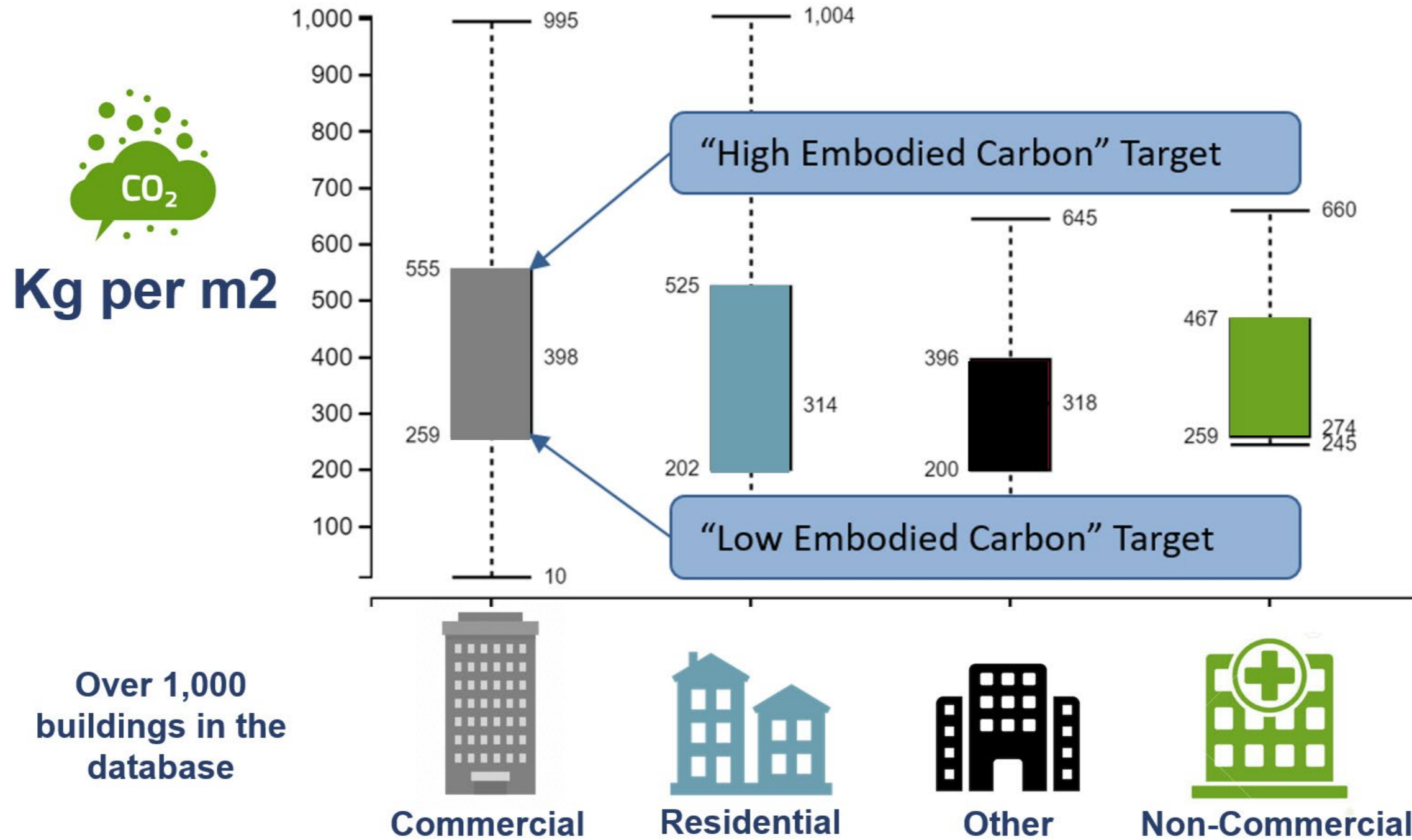

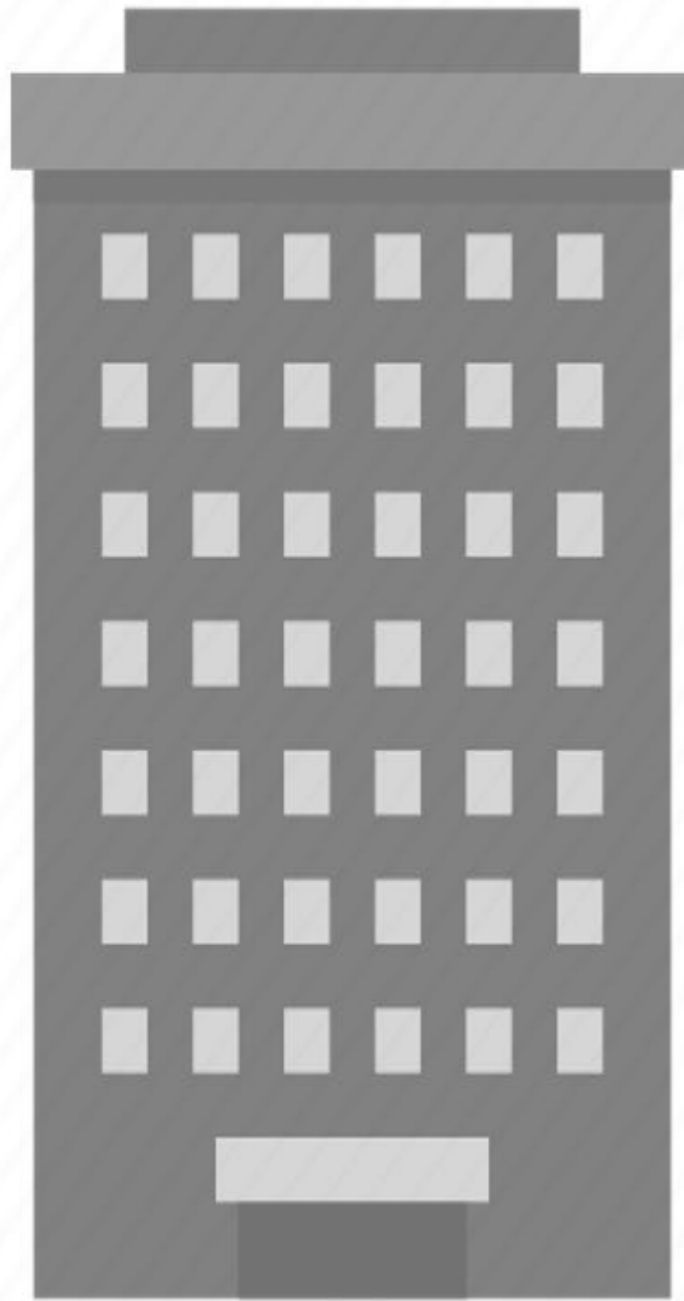

**Seattle Midrise Office**



**16% operational**  
**84% embodied**  
(over 50 life cycle)

**55,000 tons of CO<sub>2</sub>**



Or... a  flying for 70 days

Or... 10,762  driving for 1 year

Or... 172,897  of crude oil



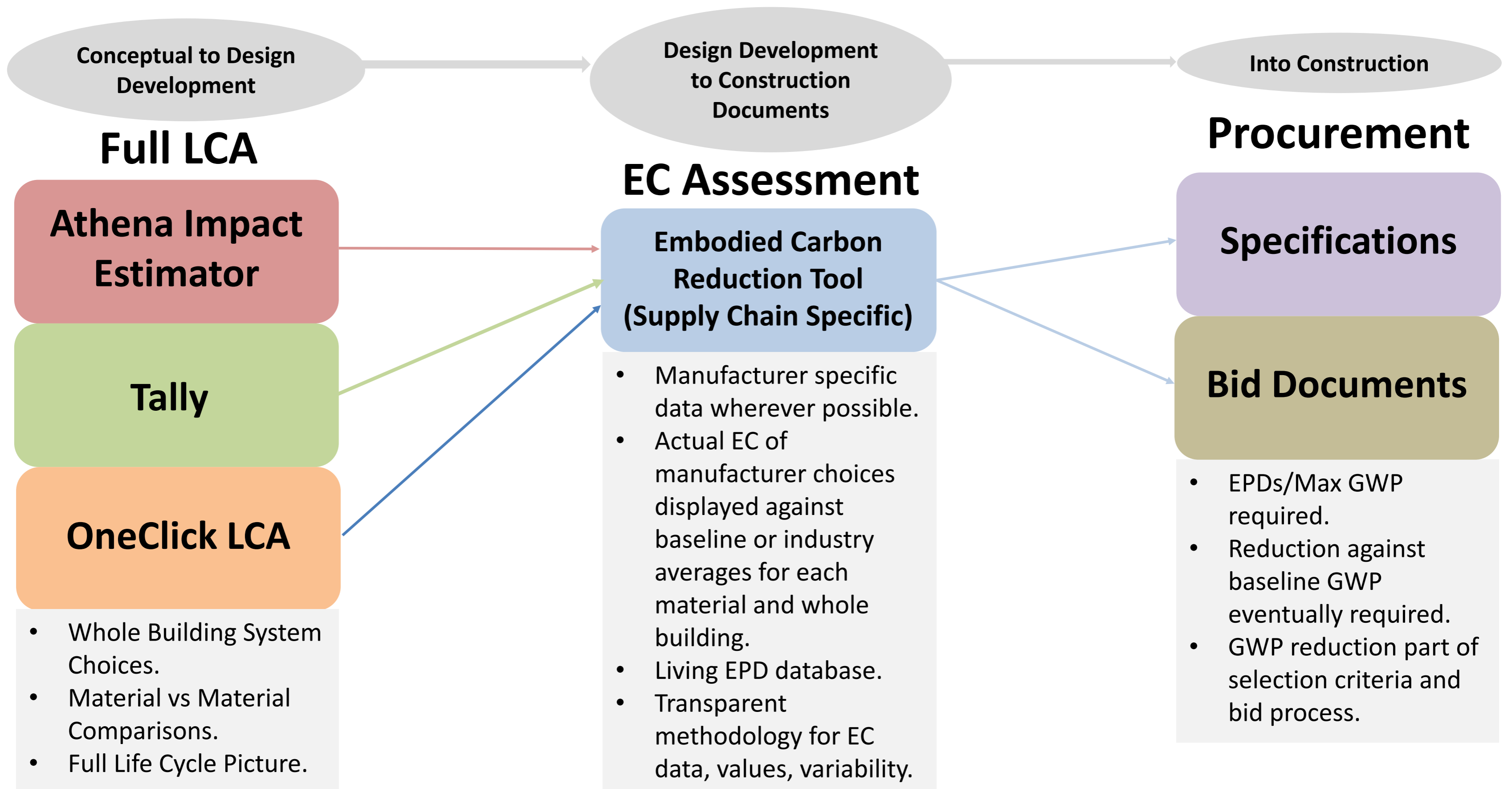

Embodied Carbon  
Reduction Tool  
(Supply Chain Specific)



- Wish List
- Available to Everyone
- Easy to Use
- Free to Use
- Open & Transparent Data Source
- Open API (willing/able to share data with other tools)
- Focused on Supply Chain Accountability





## Embodied Carbon Calculator for Construction

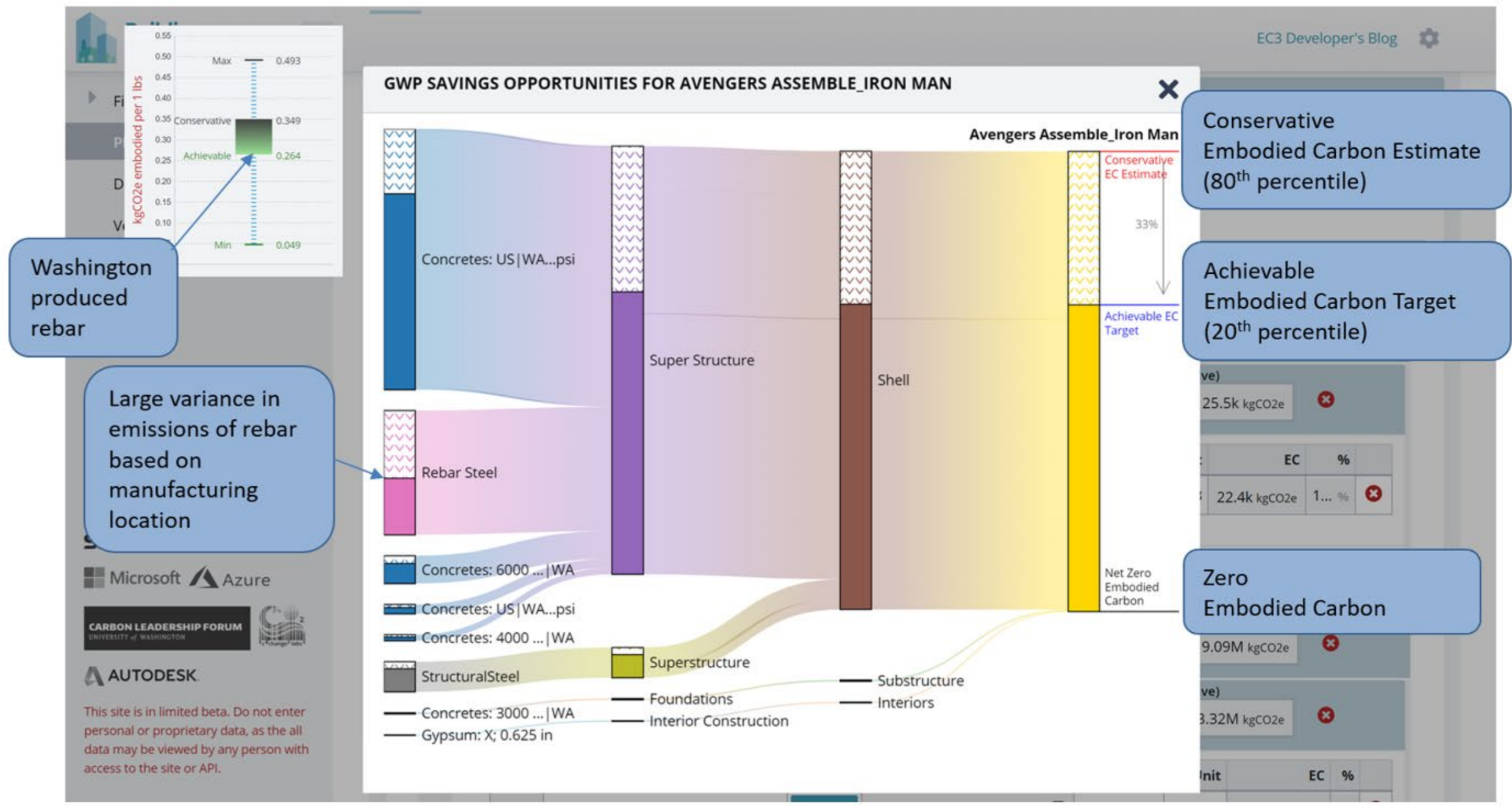

# Material Quantities

## ASTM Uniformat II Classification for Building Elements (E1557-97)

Level 1 Major Group Elements	Level 2 Group Elements	Level 3 Individual Elements
A SUBSTRUCTURE	A10 Foundations	A1010 Standard Foundations A1020 Special Foundations A1030 Slab on Grade
	A20 Basement Construction	A2010 Basement Excavation A2020 Basement Walls
B SHELL	B10 Superstructure	B1010 Floor Construction B1020 Roof Construction
	B20 Exterior Enclosure	B2010 Exterior Walls B2020 Exterior Windows

02. Parking Garage			
A SUBSTRUCTURE			
A10 FOUNDATIONS			
A1010 Standard Foundations			
03.01 Concrete			
03300.001	Spread Footings		1,848.00 cy
03300.001	Continuous Footings		87.00 cy
03300.001	Mat Footings		1,190.00 cy
03300.001	Tower Crane Footing		93.00 cy
03.02 Rebar			
03210.600	Steel Bar Reinforcement in Spread Footings (70lbs/CY)		59.00 tons
03210.600	Steel Bar Reinforcement in Matt Foundations (110lbs/CY)		60.00 tons
03210.600	Steel Bar Reinforcement in Continuous Footings(50lbs/CY)		2.00 tons
03210.600	Steel Bar Reinforcement in Tower Crane Matt Foundations(110lbs/CY)		32.00 tons

The screenshot displays a BIM software interface with a 3D model of a building structure. The interface includes several panels and toolbars:

- Model Panel:** A search bar and a list of model elements such as "Floor [215735]", "Floor [216208]", "Floor [216527]", "Floor [492570]", "Floor [492584]", "Floor [492600]", "Lattice Girder Slab...", "Cast In Place 200", and "Precast Hollow Cor...".
- Building Transparency Panel:** Shows GWP (Global Warming Potential) values: Conservative (27519.32903857875) and Achievable (21205.6243838367).
- Properties Panel:** Displays constraints and structural properties:
  - Level: Level 4S
  - Height Offse...: -650 mm
  - Room Bound...: Yes
  - Related to M...: No
  - Structural: Yes
  - Enable Analy...: No
  - Rebar Cover ...: Foundation <75 mm>
  - Rebar Cover ...: Foundation <75 mm>
  - Rebar Cover ...: Foundation <75 mm>
  - Slope: degree
  - Perimeter: 87610.8171323783 mm
- Coordinated 3D View Panel:** A tree view showing the project hierarchy, including "Railway Station - Structure.rvt", "Analytical Model", "Analytical Model with Lc", "4. Preconstruction", "5. Construction", "6. Handover", "ProjectTb", "checklist\_e8ceb053-dbae-4430-acec-cl", and "submittals-attachments".
- Bottom Toolbar:** Contains navigation and manipulation tools like rotate, pan, zoom, and view orientation.

# Environmental Product Declarations



Nutrition Facts	
Serving Size 2/3 cup (55g)	
Servings Per Container About 8	
Amount Per Serving	
<b>Calories</b> 230	Calories from Fat 40
% Daily Value*	
<b>Total Fat</b> 8g	<b>12%</b>
Saturated Fat 1g	<b>5%</b>
Trans Fat 0g	
<b>Cholesterol</b> 0mg	<b>0%</b>
<b>Sodium</b> 160mg	<b>7%</b>
<b>Total Carbohydrate</b> 37g	<b>12%</b>
Dietary Fiber 4g	<b>16%</b>
Sugars 1g	
<b>Protein</b> 3g	

## Life Cycle Impact Results (per m<sup>3</sup>)

Declared Unit: 1 m<sup>3</sup> of 10,000 psi concrete at 28 days

OPERATIONAL IMPACTS	PerformX™ PECC10K
Plant Operating Energy (MJ)	38.6
On-Site Plant Fuel Consumption (MJ)	11.1
Concrete Batch Water (m <sup>3</sup> )	1.68E-01
Concrete Wash Water (m <sup>3</sup> )	1.91E-02
On-Site Waste Disposal (kg)	0.0
ENVIRONMENTAL IMPACTS	
Total Primary Energy (MJ)	3,017
Climate Change (kg CO <sub>2</sub> eq)	445
Ozone Depletion (kg CFC 11 eq)	1.31E-08
Acidification Air (kg SO <sub>2</sub> eq)	2.96
Eutrophication (kg N eq)	0.09
Photochemical Ozone Creation (kg O <sub>3</sub> eq)	0.61

Find & Compare Materials

- Aluminium
- Asphalt
- CeilingPanel
- Cladding
- Concretes
  - Masonry
  - Ready Mixes
  - Shotcretes
  - Slurry
- Flooring
- Gypsum
- Insulation
- Steel
- Timber
- WindowOpenings
- Other Materials

CONCRETE SEARCH BY PROPERTIES

DESIGN INTENT

Compressive Strength:  @ Curing Time:   @ Curing Time:

Slump (min):  Options:  ≤ W/C Ratio:  ≥ SCM:  ≤ GWP:

GEOGRAPHIC

Filter by Country/Region:  Filter by State/Province:

ADVANCED

Filter by Product Name

Filter by Product Description

Filter by Industry standards:

Valid EPDs after:

SAVE OR RESTORE

Jurisdiction : US|CA X and Strength @28d ≅ 5000 psi X and Valid EPDs after : 2019-05-31 X

SEARCH

SEARCH RESULTS AND STATISTICS

Samples: 1830 Achievable: 235 kgCO2e Average: 286 kgCO2e ± 59.7 kgCO2e Conservative: 333 kgCO2e Declared Unit: 1 yd3

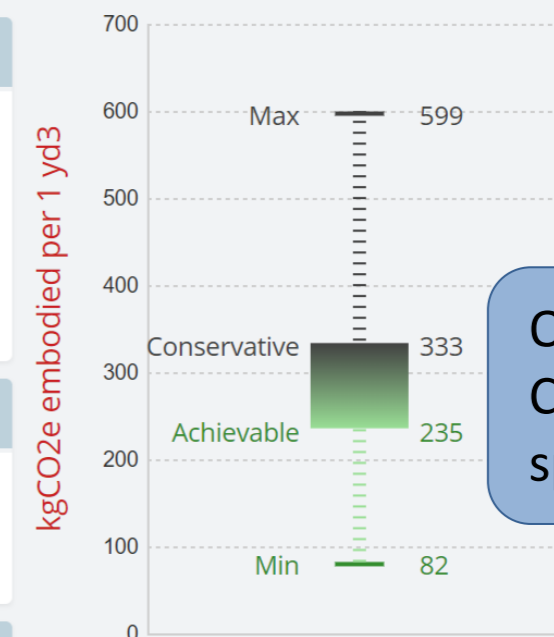

Quickly understand CO2e range of a specific material

Search by what you currently know re: material performance and criteria

Number of manufacturer EPDs currently in database that meet material parameters

Sort compliant manufacturers by GWP (CO2e) to find lowest emitting options.

**SEARCH RESULTS AND STATISTICS**

Samples: 1830    Achievable: 235 kgCO2e    Average: 286 kgCO2e ± 59.7 kgCO2e    Conservative: 333 kgCO2e    Declared Unit: 1 yd3

Subcategory	Manufact...	Plant	Product	Description	Strength ...	≤ GWP per 1 ...	Details
Ready Mixes	CENTRAL CONC...	Pleasanton (wet)	Mix PFF1157C	SP 0.55W/C 3/4...	5000 psi	104 kgCO2e	<a href="#">Details</a>
Ready Mixes	CENTRAL CONC...	Queens Lane (...)	Mix PFF1157C	SP 0.55W/C 3/4...	5000 psi	112 kgCO2e	<a href="#">Details</a>
Ready Mixes	CENTRAL CONC...	Queens Lane (d...	Mix PFF1157C	SP 0.55W/C 3/4...	5000 psi	112 kgCO2e	<a href="#">Details</a>
Ready Mixes	CENTRAL CONC...	Hayward	Mix PFF1157C	SP 0.55W/C 3/4...	5000 psi	114 kgCO2e	<a href="#">Details</a>
Ready Mixes	CENTRAL CONC...	Oakland	Mix PFF1157C	SP 0.55W/C 3/4...	5000 psi	117 kgCO2e	<a href="#">Details</a>
Ready Mixes	CENTRAL CONC...	Martinez	Mix PFF1157C	SP 0.55W/C 3/4...	5000 psi	117 kgCO2e	<a href="#">Details</a>
			57C	SP 0.55W/C 3/4...	5000 psi	121 kgCO2e	<a href="#">Details</a>
			57C	SP 0.55W/C 3/4...	5000 psi	122 kgCO2e	<a href="#">Details</a>
			57C	SP 0.55W/C 3/4...	5000 psi	122 kgCO2e	<a href="#">Details</a>
			57C	SP 0.55W/C 3/4...	5000 psi	123 kgCO2e	<a href="#">Details</a>
			57C	SP 0.55W/C 3/4...	5000 psi	123 kgCO2e	<a href="#">Details</a>
			AP1	EF 70%SCM .43...	5000 psi	130 kgCO2e	<a href="#">Details</a>
			57C	SP 0.45W/C 1" 7...	5000 psi	132 kgCO2e	<a href="#">Details</a>
			5P1	SP 0.42W/C 1" E...	5000 psi	132 kgCO2e	<a href="#">Details</a>
			57C	SP 0.45W/C 1" 7...	5000 psi	132 kgCO2e	<a href="#">Details</a>
			5P1	SP 0.42W/C 1" E...	5000 psi	132 kgCO2e	<a href="#">Details</a>
			AP1	EF 70%SCM .43...	5000 psi	134 kgCO2e	<a href="#">Details</a>

Organization Name: CENTRAL CONCRETE

Plant Name: Queens Lane (wet)

Product Name: Mix PEC1C5P1

Description: SP 0.42W/C 1" EF 3-5SL

GWP: 132 kgCO2e

Declared Unit: 1 yd3

Concrete Compressive Strength 28D: 5000 psi

Slump: 3 in - 5 in

W/C Ratio: 0.42

Aggregate Size Max: 1 in

Min Pipeline Size: 4 in

Original EPD File: [Download EPD](#)

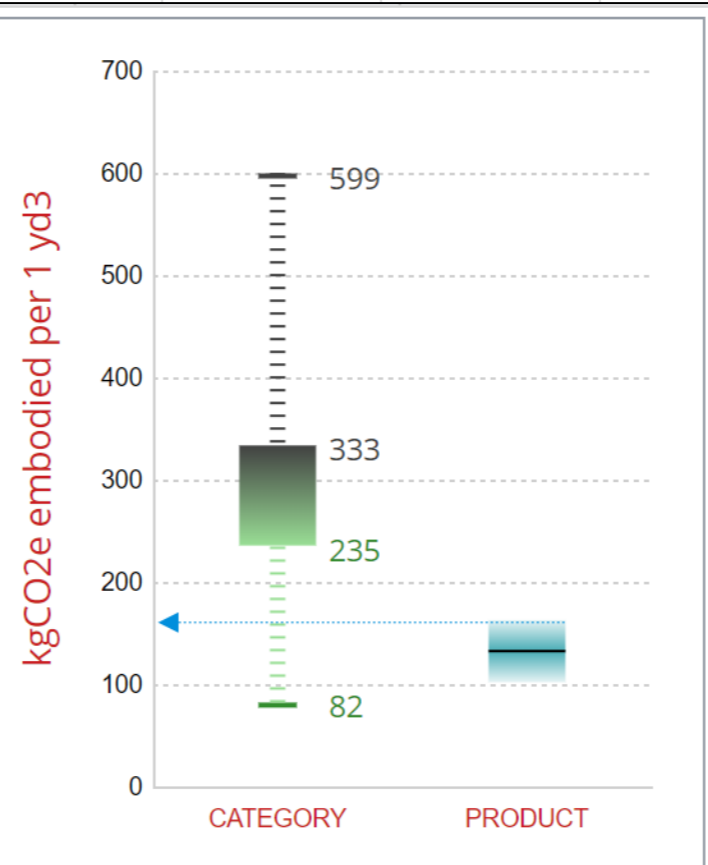

See details and automatically download the associated EPD.

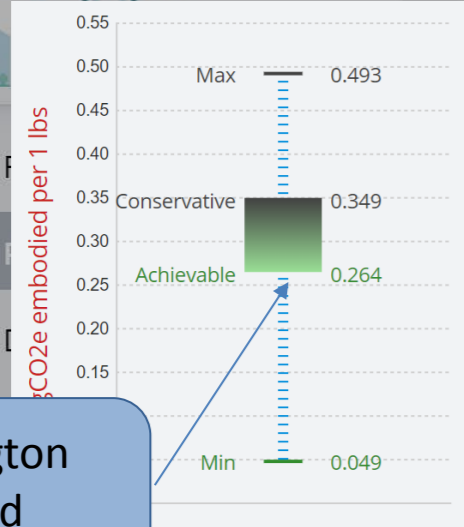

Washington produced rebar

Large variance in emissions of rebar based on manufacturing location

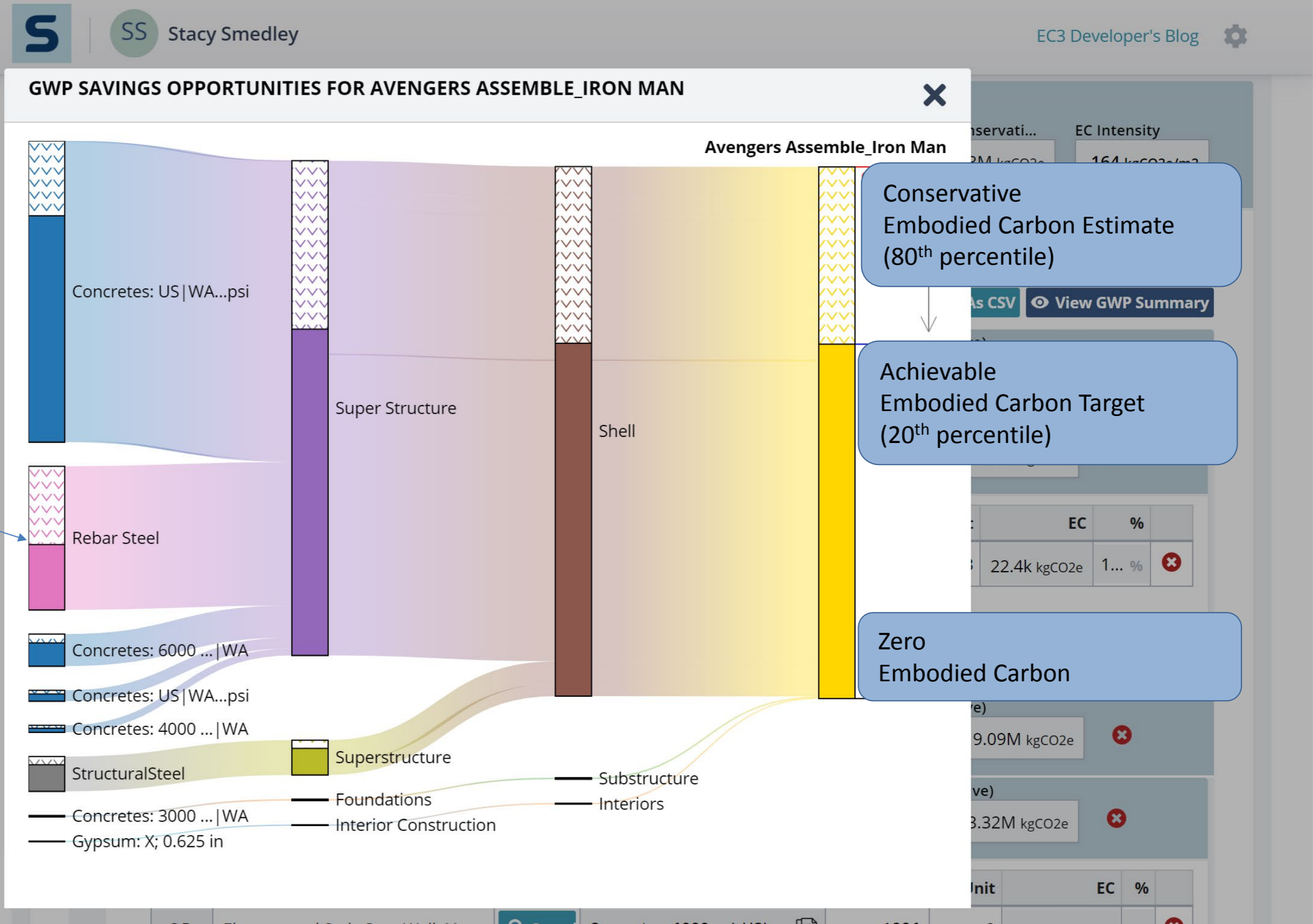

Conservative Embodied Carbon Estimate (80<sup>th</sup> percentile)

Achievable Embodied Carbon Target (20<sup>th</sup> percentile)

Zero Embodied Carbon

EC	%
22.4k kgCO <sub>2</sub> e	1... %

9.09M kgCO<sub>2</sub>e

3.32M kgCO<sub>2</sub>e

Unit	EC	%

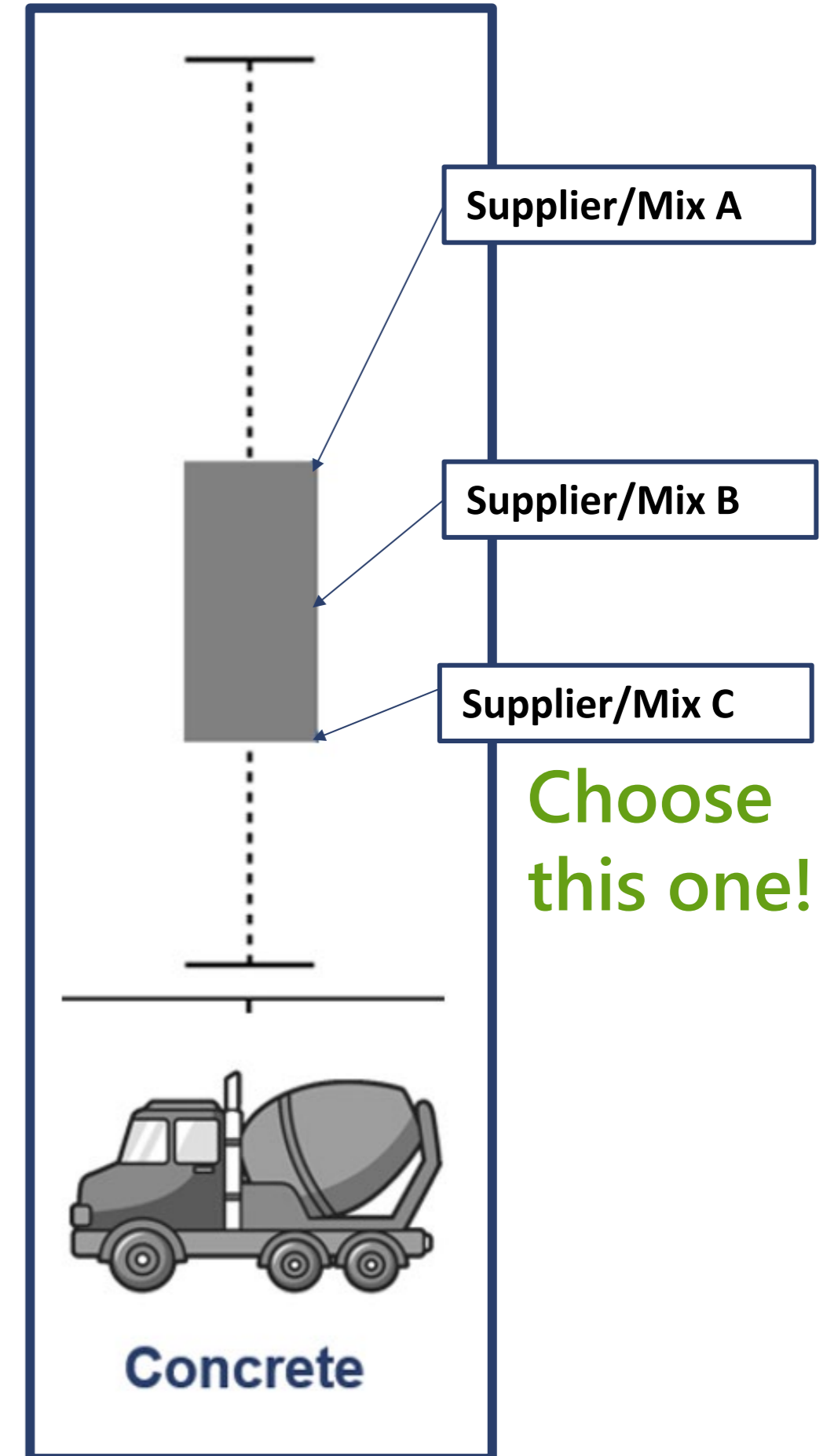
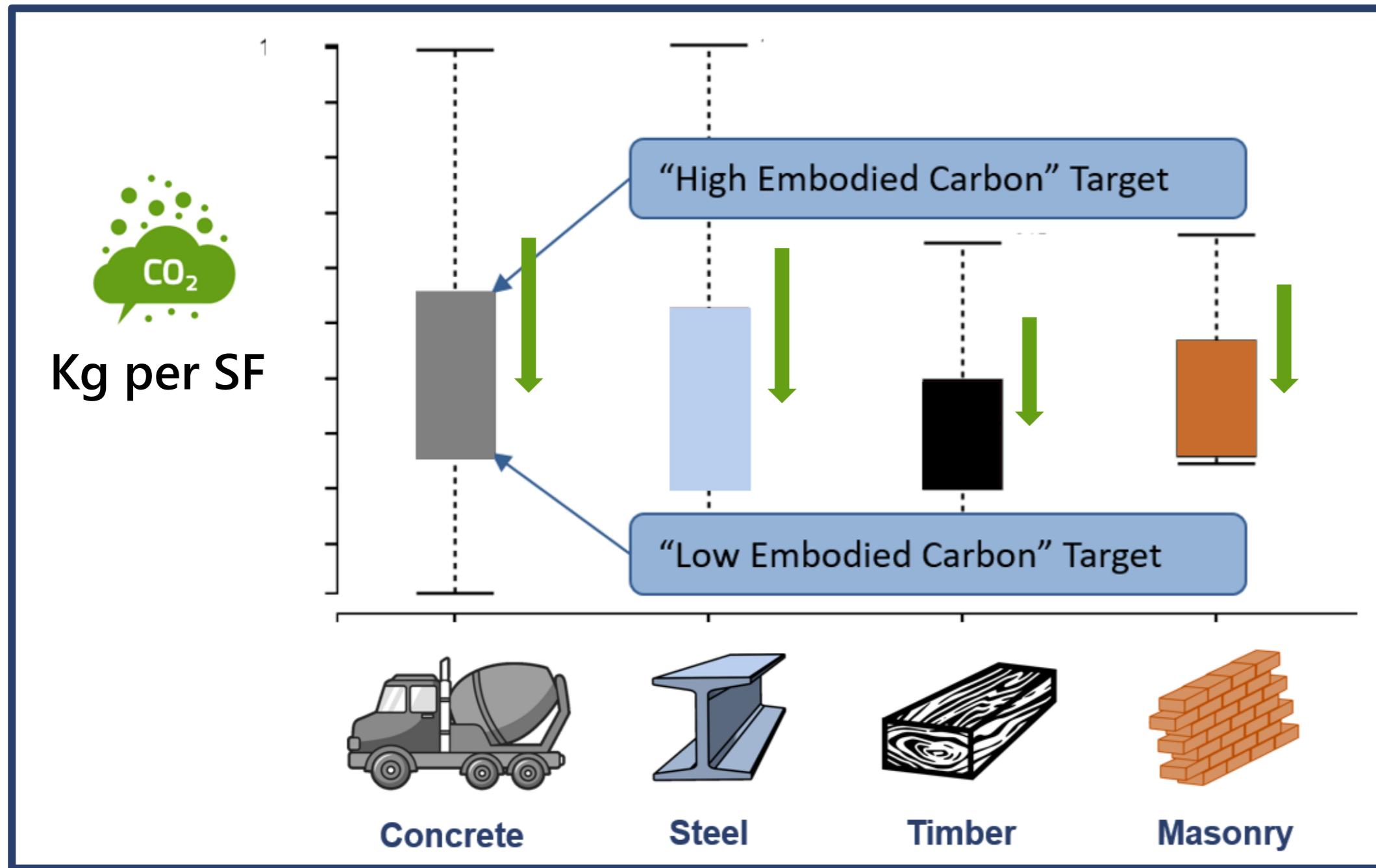

30% reduction in CO<sub>2</sub> emissions  
JUST BY having data and ASKING.

Typical 28 day cure time  
Minimal SCM's

Typical 28 day cure time  
Some SCM's

56 day cure time  
More SCM's

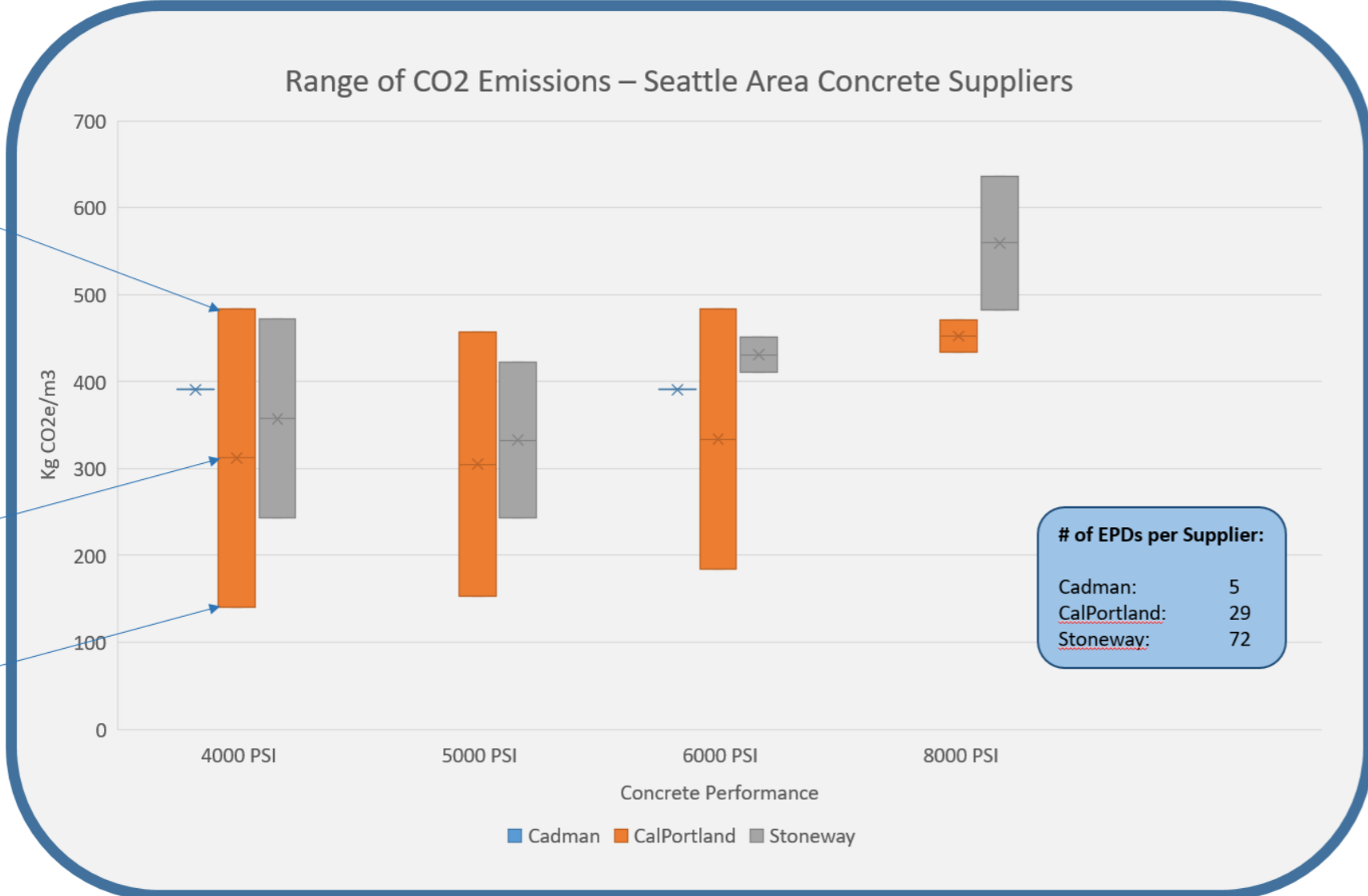

SECTION 03 30 00 – CAST-IN-PLACE CONCRETE

SUBMITTALS (added language)

A. Environmental Product Declaration (EPD): Submit in accordance with the Specification Section for LEED Submittals, Section 013510.01.B.1– Environmental Product Declarations.

1. Submit a product-specific EPD for 90% by volume for all concrete mixes used in the project in the “Concrete Mix Specification Table” within the Concrete section of the structural general notes.
2. Impact Categories:
  - a. Global Warming Potential (GWP): All GWP information submitted shall be in the form of kgCO<sub>2</sub>e/kg.
3. Plant-specific GWP information will be one of the decision criteria when awarding this scope. However, information for each impact category noted above will be reviewed. The impact category information will be evaluated against both industry average impact category datasets, as defined by National Ready Mix Concrete Association (NRMCA) regional mix EPD datasets, as well as the impact category information reported within mill-specific EPDs from competing bidders. If mill-specific impact category information is not provided, industry average EPDs will be used.

The Project has a commitment to reducing the embodied carbon footprint of the materials used in construction by a minimum of 15%, aiming to reach a 30% reduction target. Because of this mandate from the Owner and the GC team’s support of actionable carbon reduction of materials, the following items are requested as a part of the Concrete scope of work:

1. **Environmental Product Declarations (EPDs) for All Concrete Mixes Utilized on the Project:**
  - a. Subcontractor/Supplier shall provide on-demand EPDs for Project ready-mix concrete mixes, at milestones as the design progresses, to support Project emissions reductions tracking.
  - b. Project GC’s and Design Teams will provide mix performance requirements, locations and proposed schedule of pour to assist in assuring EPDs generated reflect mixes to be procured during construction.
  - c. EPDs of concrete mixes generated will be required with construction submittals to confirm carbon emissions, aka Global Warming Potentials (GWPs) of mixes installed.
2. **Actual Reductions of Carbon Emissions in Concrete Mixes Utilized on the Project:**
  - a. The Project is piloting the use of the Embodied Carbon in Construction Calculator (EC3) which includes a database of available EPDs from national materials associations (such as the NRMCA) as well as local suppliers and manufacturers of certain materials, including ready mix concrete.
  - b. The Project will utilize these available EPDs in the EC3 database to establish GWP baselines per concrete mix and enable assessment of Project specific EPD GWP numbers in order to understand reductions for the Project.
3. **As part of each Subcontractor/Supplier RFP Response, please provide a representative EPD for the following proposed concrete mixes, as provided by Project Structural Engineers. Potential GWP of each mix, provide in EPD, will be part of the assessment of each supplier’s RFP response, alongside other key metrics.**

Member	Nominal f'c*	Exposure Class **	Shrinkage Limit (%)	Max Aggregate Size	Modulus	Supplier A	Supplier B	NRMCA Industry Average (PNW)	Supplier A (compared to average)	Supplier B (compared to average)
Spread Footings/Mats	5.0 ksi					Mix 1 300 kgCO2/m3	Mix 1 530 kgCO2/m3	455.53 kgCO2/m3	-34.14%	16.35% (above the average)
Basement Walls (Shotcrete)	5.0 ksi					Mix 2 420 kgCO2/m3	Mix 2 500 kgCO2/m3	455.53 kgCO2/m3	-7.80%	9.76% (above the average)
Basement Walls (Cast-in-Place)	5.0 ksi					Mix 1 300 kgCO2/m3	Mix 3 370 kgCO2/m3	455.53 kgCO2/m3	-34.14%	-18.78%
Slab on Grade	5.0 ksi					Mix 1 300 kgCO2/m3	Mix 4 300 kgCO2/m3	455.53 kgCO2/m3	-34.14%	-34.14%
Interior Mild Slab, Beams and Columns	5.0 ksi					Mix 3 290 kgCO2/m3	Mix 1 530 kgCO2/m3	455.53 kgCO2/m3	-36.34%	16.35% (above the average)
Interior Post-tensioned Slabs	6.0 ksi/3.0 ksi at stressing					Mix 4 370 kgCO2/m3	Mix 5 440 kgCO2/m3	480.03 kgCO2/m3	-22.92%	-8.34%
Post-tensioned Slabs exposed to weather	6.0 ksi/3.0 ksi at stressing					Mix 4 370 kgCO2/m3	Mix 6 400 kgCO2/m3	480.03 kgCO2/m3	-22.92%	-16.67%
Interior Shear Walls	5.0 ksi					Mix 3 290 kgCO2/m3	Mix 7 440 kgCO2/m3	455.53 kgCO2/m3	-36.34%	-3.41%
	6.0 ksi					Mix 5 310 kg/m3	Mix 8 340 kg/m3	480.03 kgCO2/m3	-35.42%	-29.17%
	8.0 ksi					Mix 6 340 kgCO2/m3	Mix 9 325 kgCO2/m3	588.03 kgCO2/m3	-42.18%	-44.73%
Misc. Curbs/ Sidewalks/Mech. Pads	4.5 ksi				Mix 1 300 kgCO2/m3	Mix 10 375 kgCO2/m3	455.53 kgCO2/m3	-34.14%	-17.68%	
Interior Slab on Deck	5.0 ksi				Mix 3 290 kgCO2/m3	Mix 11 340 kgCO2/m3	455.53 kgCO2/m3	-36.34%	-25.36%	
								Avg Reduction	<b>-31.40% below industry avg</b>	<b>-12.99% below industry avg</b>

**Choose this one!**



Home All Materials ▾ / Concretes ▾

### CONCRETE SEARCH BY PROPERTIES

#### DESIGN INTENT

Compressive Strength

≅ 5000 psi

@ Curing Time

28d ▾

≅ Compressive Strength Other

@ Curing Time

Slump (min)

Options ▾

≤ W/C Ratio

≥ SCM

≤ GWP

#### GEOGRAPHIC

Filter by State/Province

Washington × ▾

#### ADVANCED

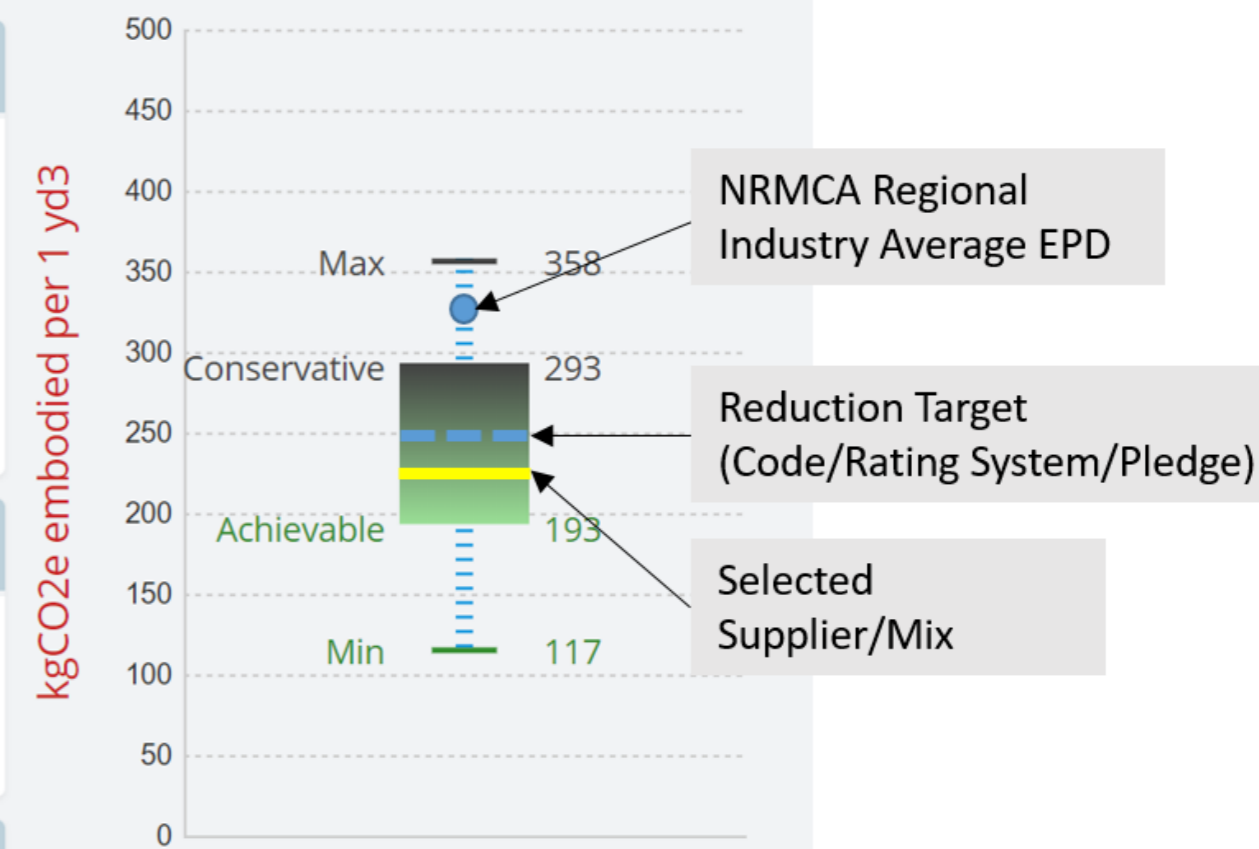

# Cities, States and the AEC Industry will lead the way.



# EMBODIED CARBON IN BUILDINGS

